



INSTALLATION AND OPERATION MANUAL

Swimming pool dehumidifier
Condair DP 270 / DP 350 / DP 450
DP 550 / DP 750 / DP 950

Thank you for choosing Condair

Installation date (MM/DD/YYYY):

Commissioning date (MM/DD/YYYY):

Site:

Model:

Serial number:

Proprietary Notice

This document and the information disclosed herein are proprietary data of Condair Group AG. Neither this document, nor the information contained herein shall be reproduced, used, or disclosed to others without the written authorisation of Condair Group AG, except to the extent required for installation or maintenance of recipient's equipment.

Liability Notice

Condair Group AG does not accept any liability due to incorrect installation or operation of the equipment or due to the use of parts/components/equipment that are not authorised by Condair Group AG.

Copyright Notice

© Condair Group AG, All rights reserved.

Technical modifications reserved.

INDEX

1. INTRODUCTION	5
1.1 Preliminary information	5
1.2 Aim and content of the manual	5
1.3 How to store this manual	5
1.4 Manual Update	5
1.5 How to use this manual	5
1.6 Potential Risks	6
1.7 General Description of Symbols Used	7
1.8 Safety symbols used	8
1.9 Limitations and prohibited use	8
1.10 Unit identification	9
2. SAFETY	10
2.1 Warning re potentially hazardous toxic substances	10
2.2 Refrigerant handling	10
2.3 Prevent inhalation of high vapor concentration	11
2.4 Procedures to be adopted in the event of accidental release of refrigerant	11
2.5 Main Toxicological Information Regarding the Type of refrigerant used	11
2.6 First Aid Measures	11
3. TECHNICAL CHARACTERISTICS	12
3.1 Unit description	12
3.2 Accessories	13
3.3 Technical data	14
3.4 Operation limits	20
3.5 Sound data	21
3.7 Safety devices	21
4. INSTALLATION	22
4.1 General safety guidelines and use of symbols	22
4.2 Health and safety Considerations	22
4.3 Personal protective equipment	22
4.4 Inspection	23
4.5 Storage	23
4.6 Unpacking	23
4.7 Lifting and handling	24
4.8 Location and minimum technical clearances	24
4.9 Condensate draining connections	25
4.10 How to connect the hot water coil (HOWA) + 3 way modulating valve (KIVM) (Accessory)	26
4.11 How to remove filters	27
4.12 Desuperheater connection (RP01)	28
4.13 Installation of built-in room electronic sensor (RGDD)	29
4.14 Serial interface card RS485 (INSE)	29
4.15 Connecting the unit to air duct channels	29
4.16 Fan positioning	31
4.17 Remote mechanical hygostat installation (HYGR)	31
4.18 Electric connections: preliminary safety information	33
4.19 Electrical data	34
4.20 How to connect the power supply	34
4.21 Electric connections	35
4.22 Refrigerant circuit layout	36
5. UNIT START UP	36
5.1 Preliminary checks	36
5.2 Description of the control panel	37
5.3 Remote control panel	38
6. USE	40
6.1 Switch the unit on	40
6.2 Stop	42

6.3 Stand-by	42
6.4 How to change the set points	42
6.5 Acoustic signal silencing	43
6.6 Display during alarm	43
6.7 Alarm reset.....	43
7. MAINTENANCE OF THE UNIT	44
7.1 General warnings.....	44
7.2 Drive access	45
7.3 Scheduled maintenance	45
7.4 Periodical checks.....	45
7.5 Refrigerant circuit repair	47
8. DECOMMISSIONING.....	48
8.1 Disconnect the unit	48
8.2 Disposal, recovery and recycling	48
8.3 RAEE Directive (only UE).....	48
9. DIAGNOSIS AND TROUBLESHOOTING	49
9.1 Fault finding	49
10.DIMENSIONAL DRAWINGS	50
11. EU DECLARATION OF CONFORMITY	54
12. MAINTENANCE AND SERVICE REPORT	55

1. INTRODUCTION

1.1 Preliminary information

Reproduction, storage or transmission of any part of this publication in any form, without the prior written consent of the Company, is prohibited.

The unit to which these instructions refer, is designed to be used for the the purposes described and to be operated in accordance with these instructions.

The Company will not be liable for claims for damage caused to persons, animals, material goods or property caused by improper installation, adjustment and maintenance or improper use. Any use not specified in this manual is prohibited.

This document is intended to provide information only and does not form a contract with third parties.

The Company pursues a policy of constant improvement and development of its products and therefore reserves the right to change the specifications and the documentation at any time, without notice and without obligation to update existing equipment.

1.2 Aim and content of the manual

These instructions are intended to provide the information required for the selection, installation, use and maintenance of the unit.

They have been prepared in accordance with the European Union laws and with the technical standards in force at the date of issue of the instructions.

The instructions contain all the necessary information to prevent any reasonably foreseeable misuse.

1.3 How to store this manual

The manual must be kept in a suitable place with easy access for users and operators, protected from dust and damp.

The manual must always accompany the unit during the entire life cycle of the same and therefore must be transferred to any subsequent user.

1.4 Manual Update

It is recommended that the manual is updated to the latest revision available.

If updates are sent to the customer they must be added to this manual.

The latest information regarding the use of its products is available by contacting the Company.

1.5 How to use this manual



The manual is an integral part of the unit.

Users or operators must consult the manual before performing any operation and especially so when transporting, handling, installing, maintaining, or dismantling the unit in order to eliminate uncertainty and reduce risk.



In these instructions symbols have been used (described in the following paragraphs) to draw the attention of operators and users to the operations that have a higher risk and which must be performed safely.

1.6 Potential Risks

Whilst the unit has been designed to minimize any risk posed to the safety of people who will interact with it, it has not been technically possible to eliminate completely the causes of risk. It is therefore necessary to refer to the requirements and symbolism below:

LOCATION OF RISK	POTENTIAL RISK	METHOD OF INJURY	PRECAUTIONS
Thermal heat exchangers.	Small stab wounds.	Contact	Avoid any contact, use protective gloves.
Fan and fan grilles.	Cuts, eye damage, broken bones.	Insertion of sharp objects through the grid while the fans are operating.	Never put objects through the protection grilles.
Internal component: compressors and discharge pipes	Burns.	Contact	Avoid any contact, use protective gloves.
Internal component: electric cables and metallic parts	Electrocution, severe burns.	Defect in the supply cable insulation, live metallic parts.	Adequate protection of power cables, ensure correct earthing of all metal parts.
External to unit: unit enclosure	Poisoning, severe burns.	Fire due to short circuit or overheating of the supply cable external to unit.	Size cables and mains protection system in accordance with iee regulations.
Low pressure safety valve.	Poisoning, severe burns.	High evaporating pressure causing a refrigerant discharge during maintenance.	Carefully check the evaporating pressure during the maintenance operations. Use all personal protective equipment required by the law. PPE must also protect against gas leaks from the safety valve. The outlet of these valves is directed to avoid causing damage to persons or goods.
High pressure safety valve.	Poisoning, severe burns, hearing loss.	Activation of the high pressure safety valve with the refrigerant circuit open.	If possible, do not open the refrigerant circuit valve; carefully check the condensing pressure; use all the personal protective equipment required by law. PPE must also protect against gas leaks from the safety valve. The outlet of these valves is directed to avoid causing damage to persons or goods.
Entire unit	External fire	Fire due to natural disasters or combustions of elements nearby unit	Provide the necessary fire-fighting equipment
Entire unit	Explosion, injuries, burns, poisoning, folgoramento for natural disasters or earthquake.	Breakages, failures due to natural disasters or earthquake	Plan the necessary precautions both electrical (suitable differential magneto and electrical protection of the supply lines; greatest care during the connections of the metal parts), and mechanical (special anchors or seismic vibrations to prevent breakages or accidental falls).

1.7 General Description of Symbols Used

Safety symbols combined in accordance with ISO 3864-2:



BANNED

A black symbol inside a red circle with a red diagonal indicates an action that should not be performed.



WARNING

A black graphic symbol added to a yellow triangle with black edges indicates danger.



ACTION REQUIRED

A white symbol inserted in a blue circle indicates an action that must be done to avoid a risk.

Safety symbols combined in accordance with ISO 3864-2:



The graphic symbol "warning" is qualified with additional safety information (text or other symbols).

1.8 Safety symbols used



GENERAL RISK

Observe all signs placed next to the pictogram. The failure to follow directions may create a risk situation that may be injurious to the user.



ELECTRICAL HAZARD

Observe all signs placed next to the pictogram. The symbol indicates components of the unit and actions described in this manual that could create an electrical hazard.



MOVING PARTS

The symbol indicates those moving parts of the unit that could create risk.



HOT SURFACES

The symbol indicates those components with high surface temperature that could create risks.



SHARP SURFACES

The symbol indicates components or parts that could cause stab wounds.



EARTH CONNECTION

The symbol identifies Earthing connection points in the unit.



READ AND UNDERSTAND THE INSTRUCTIONS

Read and understand the instructions of the machine before any operations.



RECOVER OR RECYCLE MATERIAL

1.9 Limitations and prohibited use

The machine is designed and built exclusively for the uses described in "Limitations of use" of the technical manual. Any other use is prohibited because it may pose a potential risk to the health of operators and users.







The unit is not suitable for operations in environments:

- excessively dusty or potentially explosive atmospheres;
- where there are vibrations;
- where there are electromagnetic fields;
- where there are aggressive atmospheres

1.10 Unit identification

Each unit has a rating plate that provides key information regarding the machine. The rating plate may differ from the one shown below as the example is for a standard unit without accessories. For all electrical information not provided on the label, refer to the wiring diagram. A facsimile of the label is shown below:

		Manufacturer: PD322111	
Condair Group AG Gwattstrasse 17 8808 Pfäffikon Switzerland			
1DP0.750S-2A <small>Modello Model</small>		123456 <small>Matricola Serial number</small>	
2 <small>Categoria PED PED Category</small>		8/2017 <small>Data di fabbricazione Manufacture date</small>	
R410A <small>Tipo refrigerante Refrigerant type</small>	2 <small>Gruppo fluido Fluid group</small>	2088 <small>GWP</small>	
8 Kg <small>Carica refrigerante Refrigerant charge</small>	16,7 ton <small>CO₂ Equivalente CO₂ Equivalente</small>		
400V-3ph-50Hz <small>Tensione-Fasi-Frequenza Voltage-Phases-Frequency</small>	37,50 A <small>F.L.A. (A)</small>	21,70 kW <small>F.L.I. (kW)</small>	
LATO BASSA PRESSIONE <small>LOW PRESSURE SIDE</small>		LATO ALTA PRESSIONE <small>HIGH PRESSURE SIDE</small>	
22 bar <small>PS</small>		42 bar <small>PS</small>	
Min -30 °C <small>Temperatura di progetto Design temperature</small>	Max +130 °C <small>Temperatura di progetto Design temperature</small>	Min -30 °C <small>Temperatura di progetto Design temperature</small>	Max +130 °C <small>Temperatura di progetto Design temperature</small>
420 Kg <small>Peso a vuoto Weight</small>			
<small>Contiene gas fluorurati ad effetto serra disciplinati dal protocollo di Kyoto Contains fluorinated greenhouse gasses covered by the Kyoto protocol</small>			
			



The product label should never be removed from the unit.

2. SAFETY

2.1 Warning re potentially hazardous toxic substances

2.1.1 Identification of the Type of Refrigerant Fluid Used: R410A

- Difluoromethane (HFC-32) 50% by weight CAS No.: 000075-10-5
- Pentafluoroethane (HFC-125) 50% by weight CAS No.: 000354-33-6

2.1.2 Identification of the Type of Oil Used.

The lubricant used is polyester oil. Please refer to the information provided on the compressor data plate.



For further information regarding the characteristics of the refrigerant and oil used, refer to the safety data sheets available from the refrigerant and oil manufacturers.

Main Ecological Information Regarding the Types of refrigerants Fluids used.



ENVIRONMENTAL PROTECTION : Read the ecological information and the following instructions carefully.

2.1.3 Persistence and degradation

The refrigerants used decompose in the lower atmosphere (troposphere) relatively quickly. The decomposed products are highly dispersible and therefore have a very low concentration. They do not influence the photochemical smog which is not among the VOC volatile organic compounds (as stipulated in the guidelines to the UNECE). The constituent refrigerants of R407C (R32, R125 and R134a), do not damage the ozone layer. These substances are regulated under the Montreal Protocol (revised 1992) and regulations EC no. 2037/200 of 29 June 2000.

2.1.4 Effects of discharges

Discharges into the atmosphere of this product does not cause a long-term contamination.

2.1.5 Exposure controls and personal protection

Wear protective clothing and gloves, protect your eyes and face

2.1.6 Professional exposure limits

R410A

HFC-32 TWA 1000 ppm

HFC-125 TWA 1000 ppm

2.2 Refrigerant handling



Users and maintenance personnel must be adequately informed about the possible risks of handling potentially toxic substances. Failure to follow such instructions can cause damage to personnel or to the unit.

2.3 Prevent inhalation of high vapor concentration

Atmospheric concentrations of refrigerant must be minimized and kept to a level that is below the occupational exposure limit. Vapor is heavier than air and can form dangerous concentrations near the ground where the ventilation rate is lower. Always ensure adequate ventilation. Avoid contact with open flames and hot surfaces as this can cause toxic and irritating decomposition products to form. Avoid contact between liquid refrigerant and the eyes or skin.

2.4 Procedures to be adopted in the event of accidental release of refrigerant

Ensure suitable personal protection (especially respiratory protection) during cleaning operations.

If deemed safe, isolate the source of the leak. If the leakage is small and if adequate ventilation is provided, allow the refrigerant to evaporate. If the loss is substantial ensure that measures are taken to adequately ventilate the area.

Contain spilled material with sand, earth or other suitable absorbent material.

Do not allow the refrigerant to enter drains, sewers or basements, as pockets of vapor can form.

2.5 Main Toxicological Information Regarding the Type of refrigerant used

2.5.1 Inhalation

A high atmospheric concentration can cause anaesthetic effects with possible loss of consciousness. Prolonged exposure may lead to irregular heartbeat and cause sudden death. Higher concentrations may cause asphyxia due to the reduced oxygen content in the atmosphere.

2.5.2 Contact with skin

Splashes of nebulous liquid can produce frostbite. Probably not hazardous if absorbed through the skin. Repeated or prolonged contact may remove the skin's natural oils, with consequent dryness, cracking and dermatitis.

2.5.3 Contact with eyes

Splashes of liquid may cause frostbite.

2.5.4 Ingestion

While highly improbable, may produce frostbite.

2.6 First Aid Measures



Adhere scrupulously to the warnings and first aid procedures indicated below.

2.6.1 Inhalation

Move the person away from the source of exposure, keep him/her warm and let him/her rest. Administer oxygen if necessary. Attempt artificial respiration if breathing has stopped or shows signs of stopping. If the heart stops, perform external heart massage. Seek medical assistance.

2.6.2 Contact with skin

In case of contact with skin, wash immediately with lukewarm water. Thaw tissue using water. Remove contaminated clothing. Clothing may stick to the skin in case of frostbite. If irritation, swelling or blisters appear, seek medical assistance.

2.6.3 Contact with eyes

Rinse immediately using an eyewash or clean water, keeping eyelids open, for at least ten minutes. Seek medical assistance.

2.6.4 Ingestion

Do not induce vomiting. If the injured person is conscious, rinse his/her mouth with water and make him/her drink 200-300ml of water. Seek immediate medical assistance.

2.6.5 Further medical treatment

Treat symptoms and carry out support therapy as indicated. Do not administer adrenaline or similar sympathomimetic drugs following exposure, due to the risk of cardiac arrhythmia.

3. TECHNICAL CHARACTERISTICS

3.1 Unit description

The dehumidifiers are expressly designed for use in swimming pools where humidity should be closely controlled in order to guarantee optimal comfort. These units are intended to be installed in a technical room close to the swimming pool. A centrifugal fan with high available static pressure allows unit connection to ductworks, both for air suction and discharge. This series comprises 6 basic models which cover a capacity range from 263 to 940 l/24h.

3.1.1 Frame

All units are made from hot-galvanised thick sheet metal, painted with polyurethane powder enamel at 180°C to ensure the best resistance against the atmospheric agents. The frame is self-supporting with removable panels. All screws and rivets are in stainless steel. The colour of the units is RAL 9006.

3.1.2 Refrigerant circuit

The refrigerant gas used in these units is R410A. The refrigerant circuit is made by using international primary brands components and according to ISO 97/23 concerning welding procedures. The refrigerant circuit includes: sight glass, filter drier, thermal expansion valve with external equalizer, Schrader valves for maintenance and control, pressure safety device (according to PED regulation).

3.1.3 Compressors

The compressors are Scroll type, with thermal overload protection by a klixon embedded in the motor winding. The compressor is mounted on rubber vibration dampers and it is supplied, standard, with sound-proof cover to reduce noise emission. The inspection is possible through the frontal panel of the unit that allows the maintenance of the compressor.

3.1.4 Condenser and evaporator

Condensers and evaporators are made of copper pipes and aluminium fins.

All evaporators are painted with epoxy powders to prevent corrosion problem due to their use in aggressive environments. The diameter of the copper pipes is 3/8" and the thickness of the aluminium fins is 0,1 mm. The tubes are mechanically expanded into the aluminium fins to improve the heat exchange factor. The geometry of these heat exchangers guarantees a low air side pressure drop and then the use of low rotation (and low noise emission) fans. All units are supplied, standard, with a powder coated steel drip tray and all evaporators are supplied with a temperature sensor used as automatic defrost probe.

3.1.5 Supply fan

The fans are made of galvanized steel, centrifugal type. It is statically and dynamically balanced and supplied. The electric motors are directly connected to the fan; they are all at 3 speeds, with integrated thermal protection. The protection class of the motors is IP 54.

3.1.6 Air filter

It is made of synthetic filtering media, undulated type, without electro-static charge; they are all removable for differential disposal. Efficiency class ePM10 50%, according to EN 16890:2017.

3.1.7 Microprocessors

All units are supplied standard with microprocessor controls. The microprocessor controls the following functions: regulation of the water temperature, antifreeze protection, compressor timing, compressor automatic starting sequence, alarm reset, potential free contact for remote general alarm, alarms and operation leds.

3.1.8 Electric enclosure

The electric switch board is made according to electromagnetic compatibility norms CEE 73/23 and 89/336. The accessibility to the board is possible after removing the front panel of the unit and the OFF positioning of the main switch. The following components are also standard installed: main switch, magnetic-thermal switches (as a protection fans and compressors), control circuit automatic breakers, compressor contactors, fan contactors. The terminal board is supplied with voltage free contacts for remote ON-OFF and general alarm.

3.1.9 Control and protection devices

All units are supplied with the following control and protection devices: antifreeze protection sensor, high pressure switch with manual reset, low pressure switch with automatic reset, high pressure safety valve, compressor thermal overload protection, fans thermal overload protection.

3.1.10 Test

All the units are fully assembled and wired at the factory, carefully evacuated and dried after leak tests under pressure and then charged with refrigerant R410A. They are all fully operational tested before shipment. They all conform to European Directives and are individually marked with the CE label and provided with Conformity Declaration.

3.2 Accessories description

3.2.1 Hot water coil (HOWA)

The heat exchanger is made of copper pipes and aluminium fins. The diameter of the copper pipes is 3/8" and the thickness of the aluminium fins is 0,1 mm. The tubes are mechanically expanded into the aluminium fins to improve the heat exchange factor.

3.2.2 Electric heater 6kW / 9kW / 18KW (HOEL)

The electric heater kit is in aluminium and is used to integrate the unit heating capacity. The kit is composed of an ON-OFF double safety thermostat without capacity steps.

3.2.3 Electronic temperature and humidity probe (RGDD)

Built-in Electronic temperature and humidity probe.

3.2.4 Remote mechanical hygrostat (HYGR)

To be installed on the wall, it is supplied with a regulation knob and working range from 30% to 100% with precision of 3%.

3.2.5 3 Way on/off valve (KIVM)

It is used to control the waterflow in the coil. The valve is directly controlled from the unit microprocessor.

3.2.6 Remote control panel (PCRL)

This panel can be mounted up to 50m (maximum) from the unit and replicates all of the control functions. It is connected using a twin cable of 0.5 mm sq section.

3.2.7 Desuperheater in Cu-Ni (RP01)

The unit is fitted with a Coaxial type heat exchanger suitable for chlorinated water. The internal pipe is manufactured from Cupronickel with the external pipe being made from Copper. The chlorinated water flows within the internal pipe whilst the refrigerant gas passes through the gap between the internal and external pipes. The Cupro-nickel internal pipe is manufactured with a special profile that generates turbulent flow within the refrigerant gas thus increasing the heat exchange factor, the thermal efficiency and reducing the dimensions. The heat exchanger is designed to recover approx. 20% of the thermal capacity generated by the unit.

3.2.8 Serial interface card RS485 (INSE)

This interface card enables the controller to communicate with other devices using Modbus protocol.

3.2.9 E.C. Supply fan (VECE)

The supply fan is a high performance centrifugal type, double inlet forward curved blades, directly coupled to the electric motor. The fan wheel and the scroll are made from hot galvanised thick sheet metal, painted with polyurethane powders, to ensure the best resistance against aggressive environments. The electric motor is a high efficiency DC brushless type with external rotor, to guarantee an ideal cooling of the windings and the absence of power lost due to pulleys and belt transmission. The fan is statically and dynamically balanced class 6,3 according to ISO1940. The electric motor has a separate electronic commutator (driver) and a speed modulation 0-10V, integrated PFC, burn out thermal protection (in case of considerable reduction of the power supply), protection degree IP54, serial interface card with modbus protocol RTU.

3.2.10 Air filter with frame for ducted installation (FARC)

Complete with G5 efficiency air filter which can be removed by the side and frame for ducted installation.

3.2.11 Floor trolley version (TROL)

To facilitate dehumidifier handling where is placed.

3.2.12 Stainless steel frame (INOX)

It's used to ensure the best resistance against the atmospheric agents and the operation in aggressive environments. The frame is made of stainless steel AISI 304, self-supporting with removable panels to facilitate inspection and maintenance of internal components. All screws and rivets are in stainless steel.

3.3 Technical data

DP		270	350	450	550	750	950
Moisture removed at 30°C - 80%	l/24h	254,2	353,3	466,7	600,2	845,9	1028,0
Moisture removed at 30°C - 60%	l/24h	183,7	266,0	340,1	436,1	605,3	766,3
Moisture removed at 27°C - 60%	l/24h	162,0	234,3	303,0	377,1	536,2	682,7
Moisture removed at 20°C - 60%	l/24h	113,2	170,6	221,6	264,2	386,5	508,2
Nominal input power at 30°C-80% ⁽¹⁾	kW	4,1	5,3	8,1	9,2	14,3	18,1
Maximum input power ⁽¹⁾	kW	6,4	7,8	10,5	10,6	17,6	20,8
Supplementary electric heater	kW	9,0	9,0	9,0	18,0	18,0	18,0
Maximum input power ⁽¹⁾	A	10,8	13,0	17,1	18,3	28,6	35,2
Peak current	A	51,0	66,0	76,0	98,6	103,0	151,0
Hot water coil ⁽²⁾	kW	22,8	24,0	24,0	42,0	49,0	56,0
Partial heat recovery ⁽³⁾	kW	1,8	2,2	2,7	3,5	---	---
Air Flow	m ³ /h	3500	4200	4200	5500	7000	8500
Available static pressure	Pa	50÷150	50÷150	50÷150	50÷150	50÷150	50÷150
Refrigerant		R410a	R410a	R410a	R410a	R410a	R410a
Refrigerant charge	Kg	2088	2088	2088	2088	2088	2088
Global warming potential (GWP)		3,00	2,50	2,50	6,3	6,6	7,0
Equivalent CO ₂ charge	t	6,26	5,22	5,22	13,15	13,78	14,61
Sound power ⁽⁴⁾	dB(A)	70	71	71	73	73	73
Sound pressure ⁽⁵⁾	dB(A)	54	55	55	56	56	56
Power supply	V/Ph/Hz	400/3+N/50	400/3+N/50	400/3+N/50	400/3+N/50	400/3+N/50	400/3+N/50

Performances are calculated with low fan speed and are referred to the following conditions:

(1) Without electric heater.

(2) Room temperature 30°C; water temperature 80/70°C, compressor OFF.

(3) Room temperature 30°C/80%; water temperature 30/35°C.

(4) Sound Power level according to ISO 9614 fan with available static pressure 50 Pa.

(5) Sound Pressure level measured at 1 mt from the unit in free field conditions according with ISO 9614, fan with available static pressure 50 Pa.



The refrigerant data may change without notice. It is therefore necessary to refer always to the silver label placed on the unit.

3.3.1 Hot water coil (Accessory)(HOWA)

DP		270	350	450	550	750	950
Nominal capacity	kW	22,8	24,0	24,0	42,0	49,0	56,0

Performances are referred to the following conditions:
 Room temperature 30°C; water temperature 80/70°C, compressor switched off.

3.3.2 Hot water coil correction factors (HOWA)

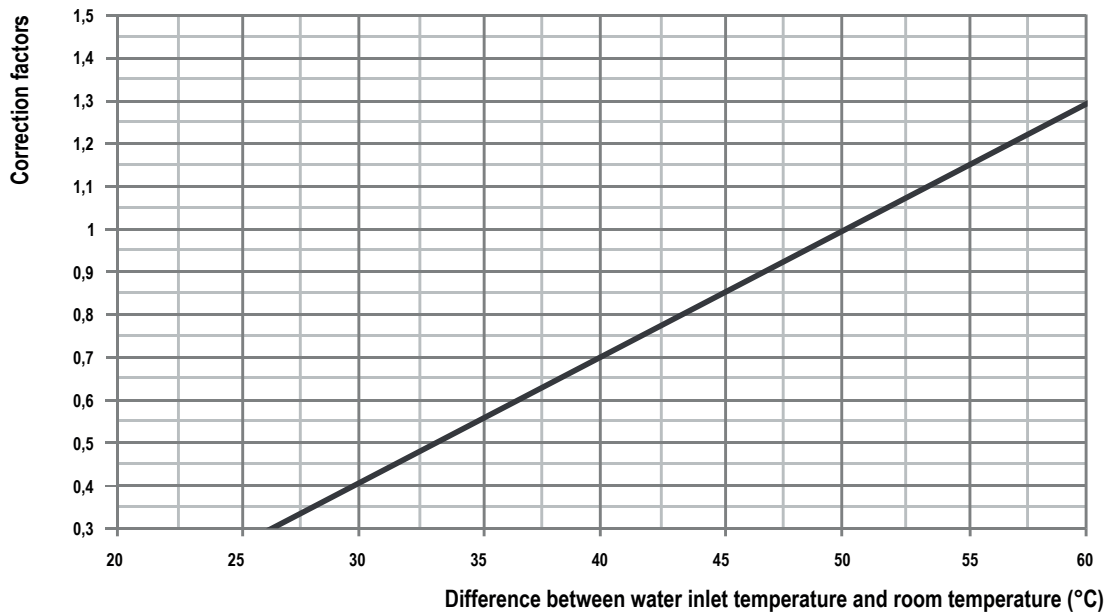

The hot water coil capacity in different conditions can be obtained multiplying the nominal capacity (See above), by the correction factor indicated in the table.

3.3.3 Pressure drops of hot water coil hydraulic circuit

The graphic below shows the pressure drops of the hydraulic circuit that includes the hot water coil and the 3 way modulating valve.

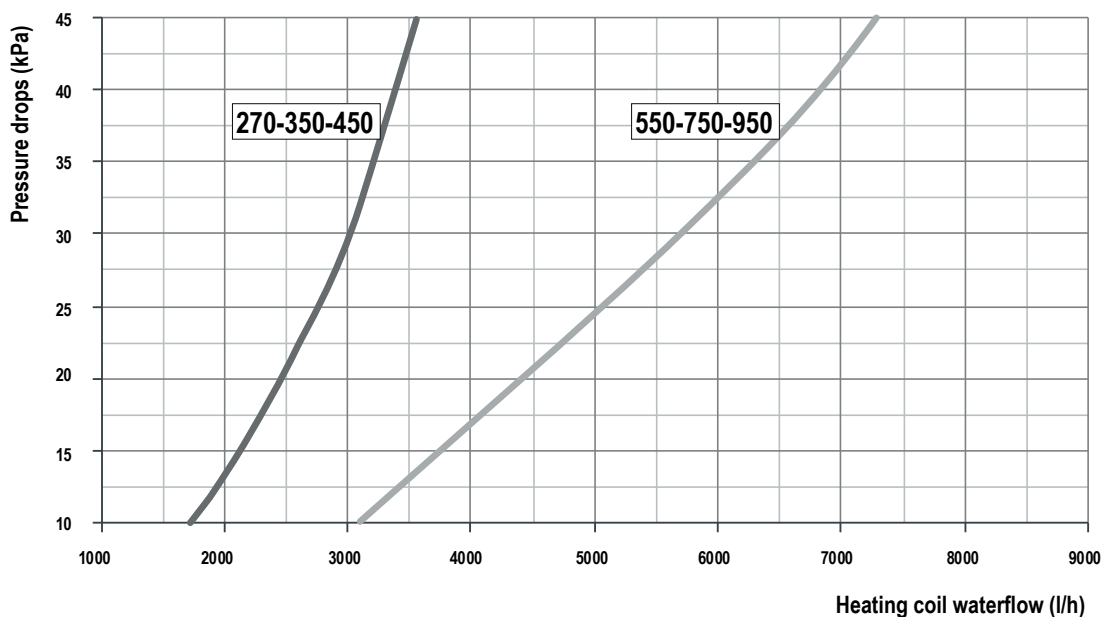

3.3.4 Desuperheater (Accessory)(RP01)

DP		270	350	450	550	750	950
Nominal capacity	kW	6	7	7	13	15	17

Performances are referred to the following conditions:
 Room temperature 30°C; water temperature 30/35°C, compressor switched off.

3.3.5 Desuperheater correction factors

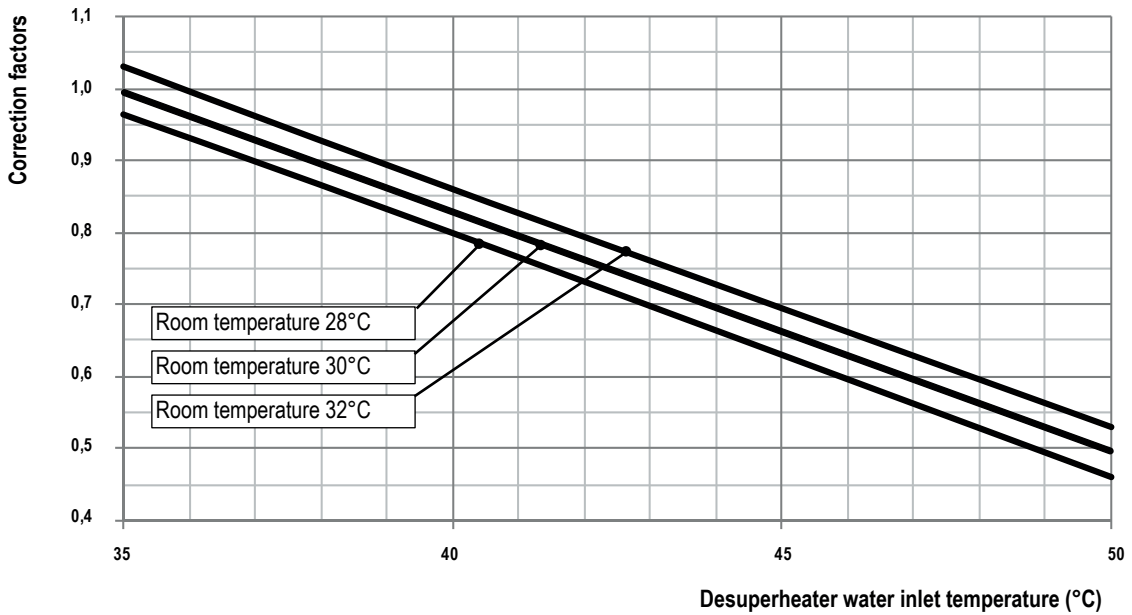

The desuperheater capacity in different conditions can be obtained multiplying the nominal capacity (See above), by the correction factor indicated in the table.

3.3.6 Pressure drops of desuperheater

The graphic below shows the pressure drops of the hydraulic circuit that includes the desuperheater.

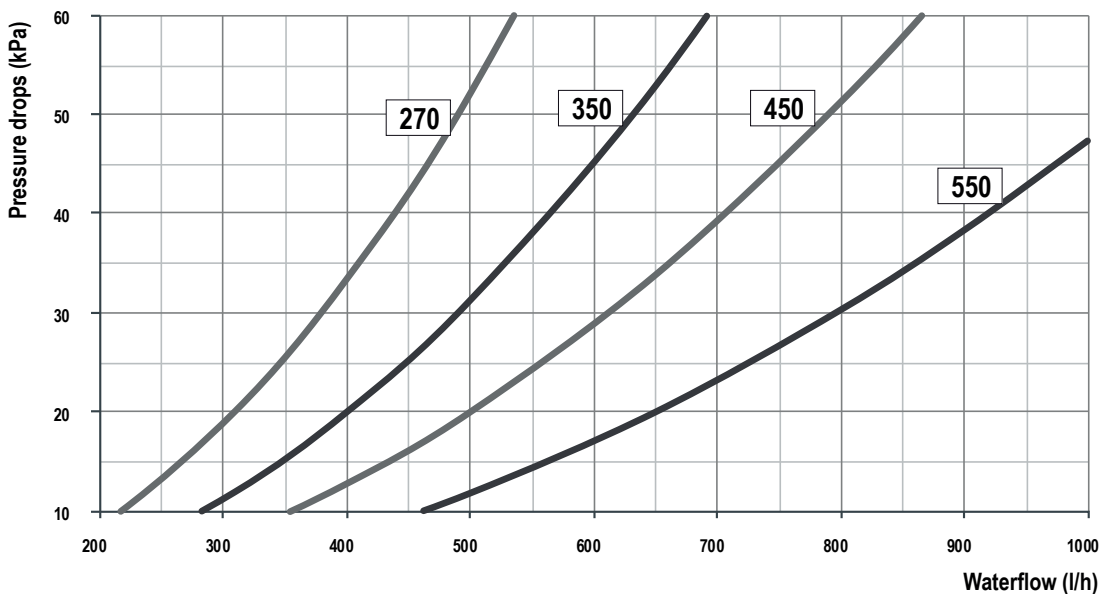

3.3.7 Fans

DP 270

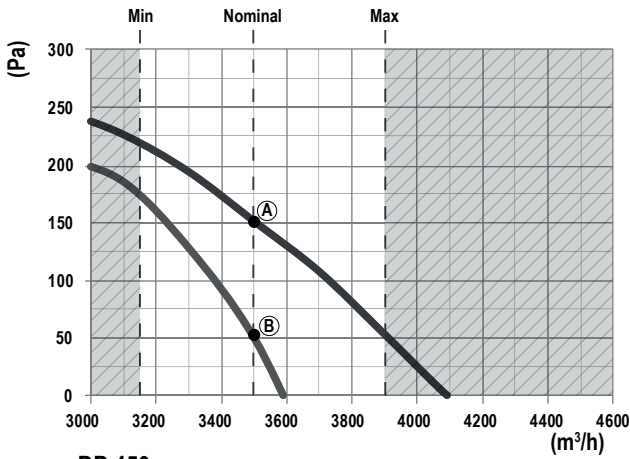

DP 350

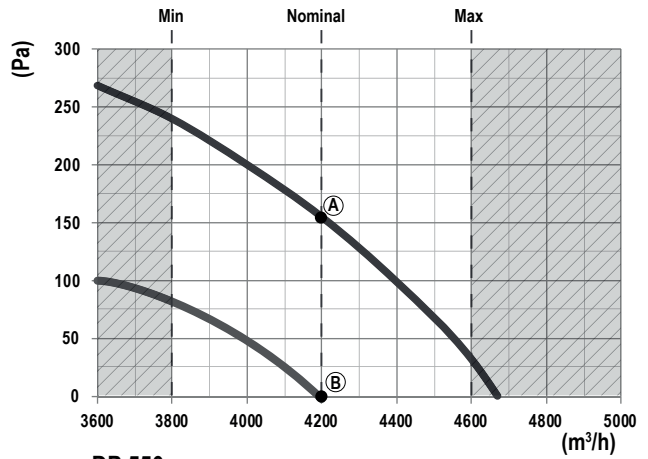

DP 450

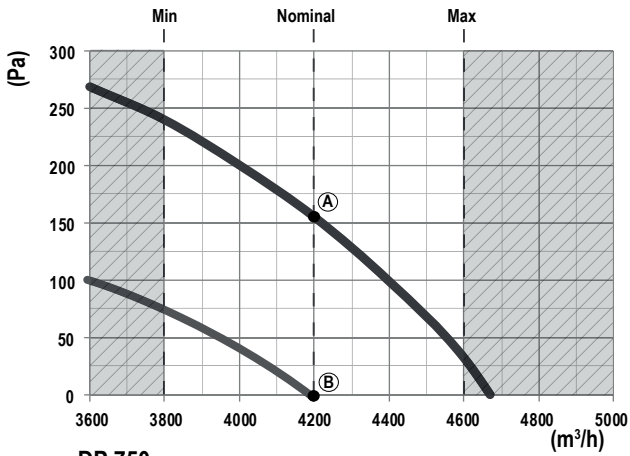

DP 550

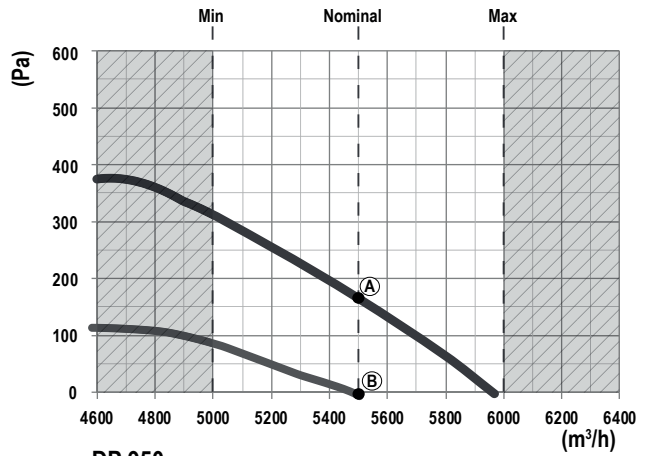

DP 750

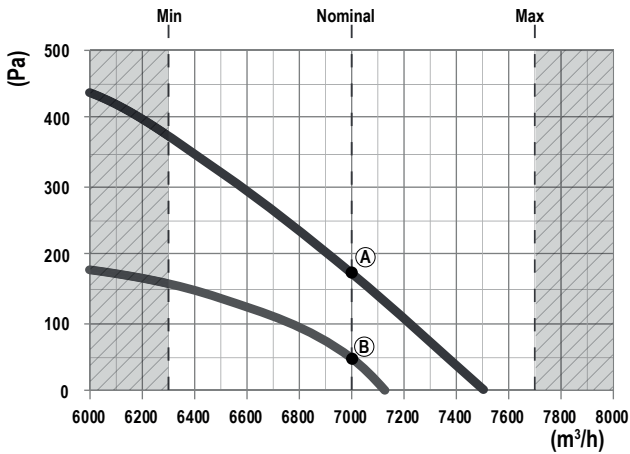

DP 950

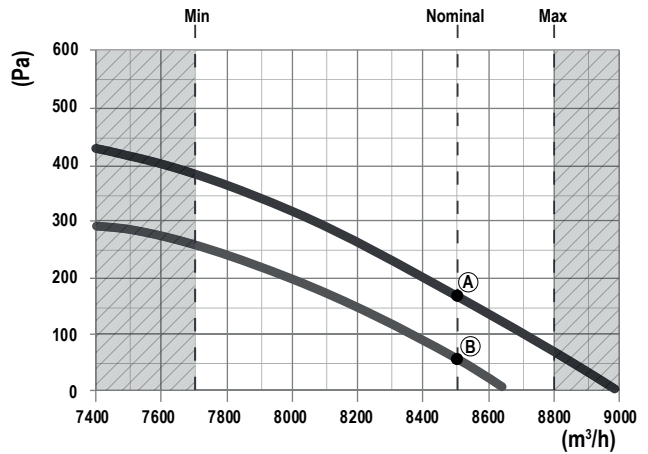

			270	350	450	550	750	950
A (High speed)	Input power	kW	0,73	1,36	1,36	1,53	3,30	3,80
	Input current	A	1,50	2,80	2,80	3,60	5,50	6,70
B (Low speed)	Input power	kW	0,68	0,73	0,73	1,18	3,10	3,60
	Input current	A	1,40	1,50	1,50	2,20	5,20	6,40



In order to enable the proper functioning of the unit is important to ensure a constant air flow to the unit close to the nominal stated value. The maximum deviation allowed is 10%.

3.3.8 E.C. Supply fan (VECE) (accessory)

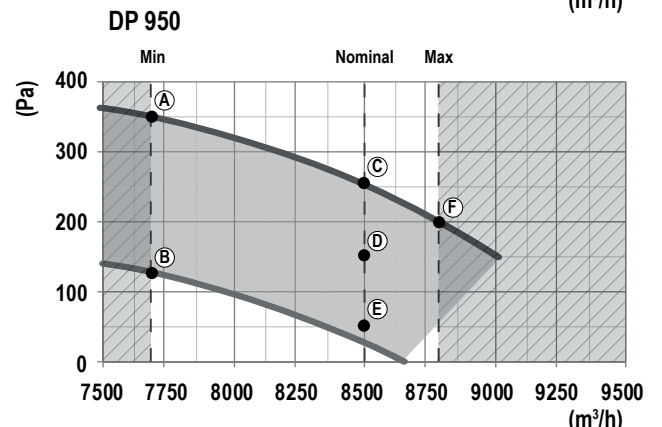
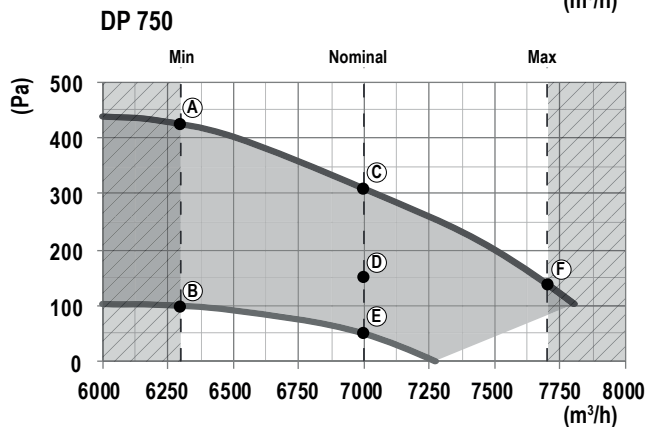
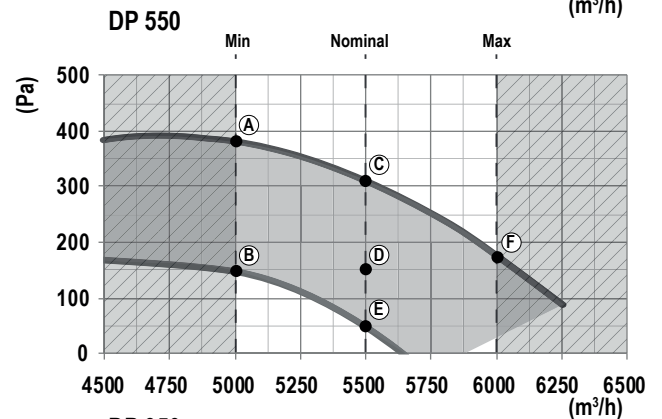
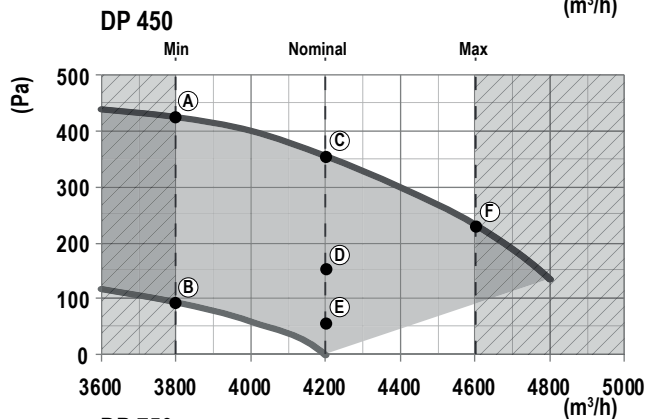
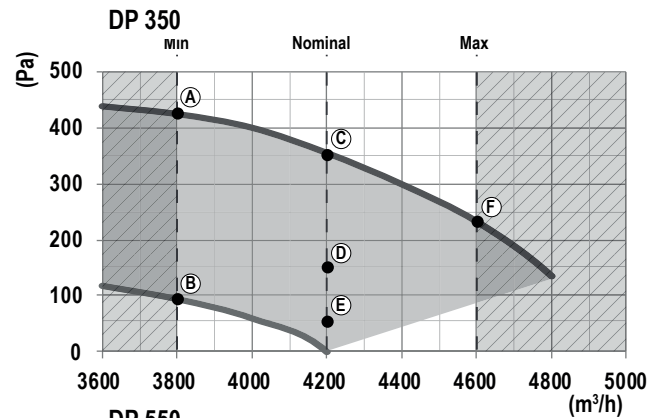
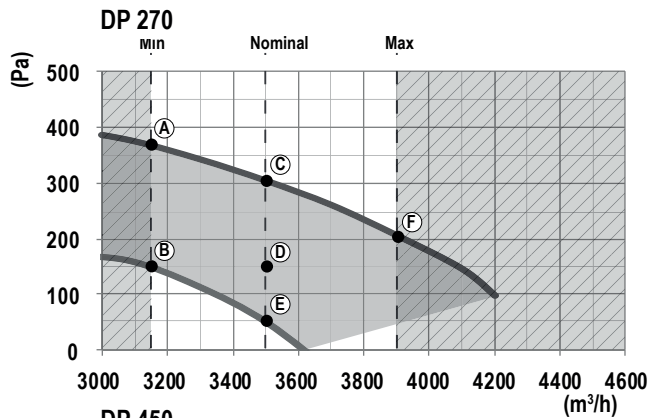

	EC fan electrical data											
	270		350		450		550		750		950	
	kW	A	kW	A	kW	A	kW	A	kW	A	kW	A
A	0,76	3,30	1,11	4,80	1,11	4,80	1,53	2,70	2,34	3,90	3,16	5,10
B	0,46	2,00	0,55	2,40	0,55	2,40	0,95	1,70	1,48	2,60	2,42	4,10
C	0,75	3,20	1,16	5,00	1,16	5,00	1,53	2,70	2,43	4,00	3,52	5,60
D	0,55	2,40	0,78	3,30	0,78	3,30	1,07	2,06	2,04	3,44	3,14	5,07
E	0,44	1,90	0,62	2,70	0,62	2,70	0,92	1,69	1,70	3,01	2,75	4,57
F	0,73	3,10	1,14	4,90	1,14	4,90	1,49	2,60	2,42	4,10	3,60	5,70



In order to enable the proper functioning of the unit is important to ensure a constant air flow to the unit close to the nominal stated value. The maximum deviation allowed is 10%.

3.3.9 Supply fan Microswitches (Only with VECE)

All units equipped with EC fans are supplied with micro switches for the management of the speed of rotation. The micro switches configuration is done at the factory but can be modified by the user according to the specific plant requirements. Indicatively it can be considered that the displacement of the micro switch from one number to the next or previous leads to an increase/decrease of the available static pressure of about $30 \div 50$ Pa at nominal air flow.



All units are factory set with the nominal air flow rates and available static pressure of 150 Pa .

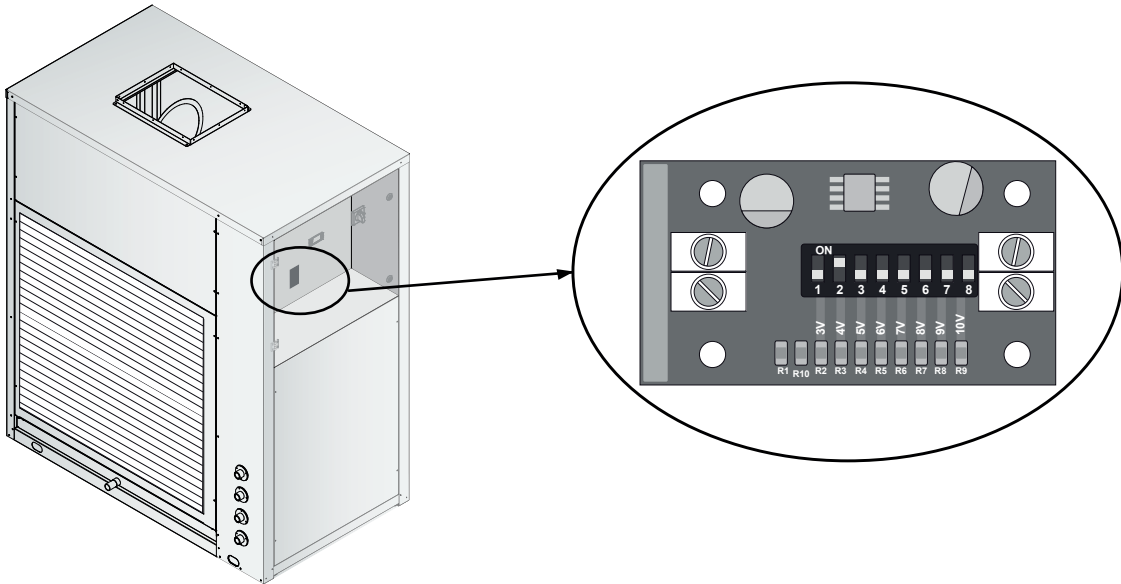

3.3.10 Fan speed setting

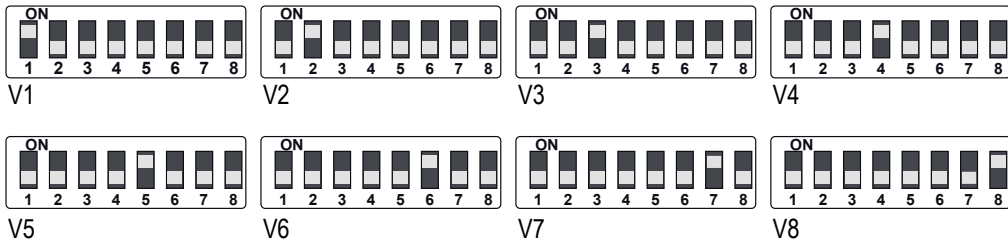

V1 = Minimum speed V8 = Maximum speed



The use of the minimum speed (1 and 2) must be carefully evaluated by skilled personnel because the operation at very low fan speed could result in malfunction or even damage to the unit.

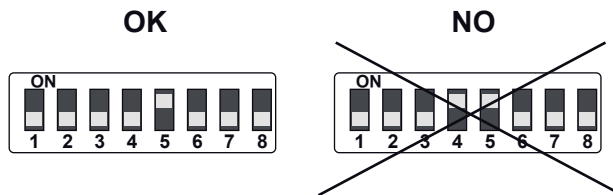

It is recommended to move a single micro switch for each operating speed . The displacement of two or more micro switches may generate incorrect power supply voltages with malfunction or damage to the unit .

3.4 Operation limits

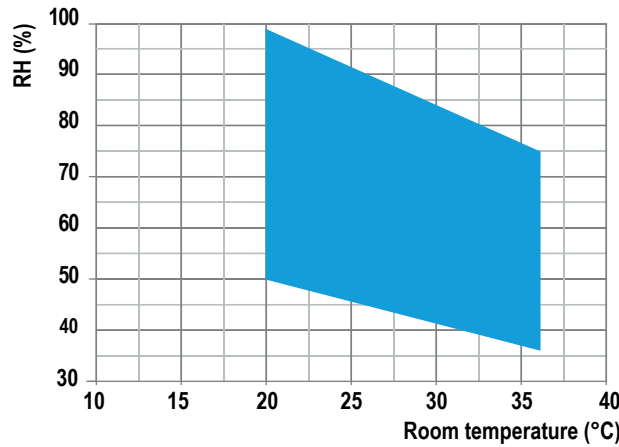

All the units can run with room humidity or external humidity between 50% and 99% as shown in the chart.



The units **MUST** be used within the operation limit indicated in the diagrams (see above). the warranty will be invalidated if the units are used in ambient conditions outside the limits reported. If there is the necessity to operate in different conditions, please contact our technical office.



Units are designed to operates with hot water coil supply temperature variables from 55°C to 80°C



The units are designed to operate within false ceiling and/or heated technical room. The units are **NOT** suitable for outdoor installations and / or technical room w/o heat (attics, rooms communicating with the outside) as it may form condensation on the walls and inside the unit cabinet causing damages.



In the case of HOWA or HOEL accessories, the maximum ambient temperature is limited by 5K.

3.4.1 Maximum pool water chlorine content

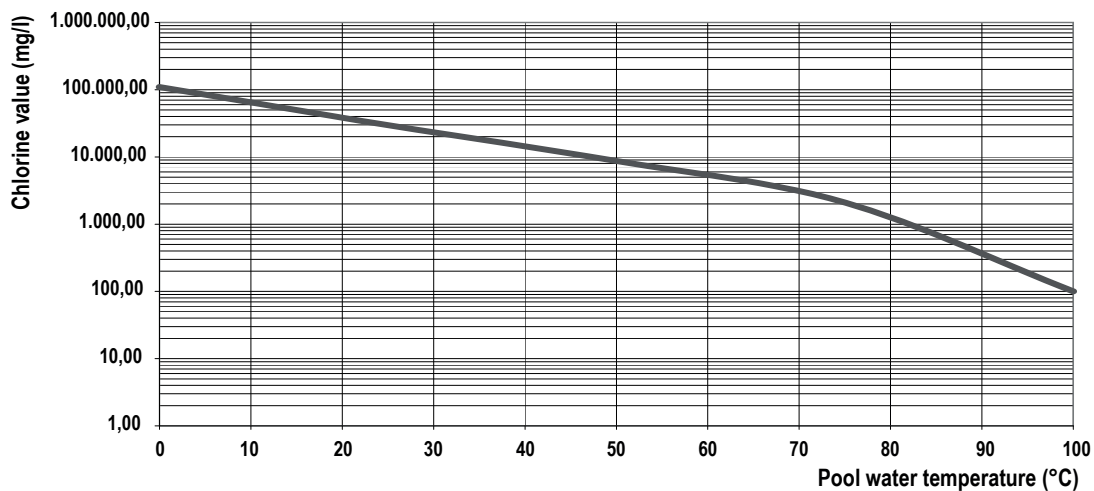

The units are designed and manufactured to operate with pool water chlorine values below the limits shown in the graph. Chlorine values above this limit can irreparably damage the unit.

3.5 Sound data

Sound data										
Modd.	Octave band (Hz)								Lw	Lp
	63 dB(A)	125 dB(A)	250 dB(A)	500 dB(A)	1K dB(A)	2K dB(A)	4K dB(A)	8K dB(A)	dB(A)	dB(A)
270	83,1	74,3	68,2	66,7	65,6	60,2	56,8	47,7	70	54
350	84,1	75,3	69,2	67,7	66,6	61,2	57,8	48,7	71	55
450	84,1	75,3	69,2	67,7	66,6	61,2	57,8	48,7	71	55
550	86,1	77,3	71,2	69,7	68,6	63,2	59,8	50,7	73	56
750	86,1	77,3	71,2	69,7	68,6	63,2	59,8	50,7	73	56
950	86,1	77,3	71,2	69,7	68,6	63,2	59,8	50,7	73	56

Lw: Sound power level according to ISO 9614 fan with available static pressure 50 Pa.

Lp: Sound pressure level measured at 1 mt from the unit in free field conditions direction factor Q=2 according to ISO 9614 fan with available static pressure 50 Pa.

3.6 Safety devices

3.6.1 High pressure switch

The high pressure switch stops the unit when the discharge compressor pressure is higher than the set value. The restart is automatic, done when the pressure is under the level set in the differential value.

3.6.2 Defrost sensor

It's a device which signals to the electronic control, the necessity to make the defrost cycle. Once the defrost cycle is activated, the defrost sensor determines also its conclusion.

3.6.3 Defrosting

The frost on the coil, obstructs the air flow, reduces the available exchange area and consequently the unit performances and can seriously damage the system. All the units are supplied, standard, with a control which defrost automatically the heat exchanger if necessary. This control provides a temperature probe (defrost thermostat) on the unit evaporator. When the defrost cycle is required, the microprocessor control (according to set parameters), switches the compressor off, while the fan remains in operation. At the end of the defrost cycle, it is waited for the dripping time to allow the complete cleaning of the coil.

4. INSTALLATION

4.1 General safety guidelines and use of symbols



Before undertaking any task the operator must be fully trained in the operation of the machines to be used and their controls. They must also have read and be fully conversant with all operating instructions.



All maintenance must be performed by TRAINED personnel and be in accordance with all national and local regulations.



The installation and maintenance of the unit must comply with the local regulations in force at the time of the installation.



Avoid contact and do not insert any objects into moving parts.

4.2 Health and safety Considerations



The workplace must be kept clean, tidy and free from objects that may prevent free movement. Appropriate lighting of the work place shall be provided to allow the operator to perform the required operations safely. Poor or too strong lighting can cause risks.



Ensure that work places are always adequately ventilated and that respirators are working, in good condition and comply fully with the requirements of the current regulations.

4.3 Personal protective equipment



When operating and maintaining the unit, use the following personal protective equipment listed below as required by law.



Protective footwear.



Eye protection.



Protective gloves.



Respiratory protection.



Hearing protection.

4.4 Inspection

When installing or servicing the unit, it is necessary to strictly follow the rules reported on this manual, to conform to all the specifications of the labels on the unit, and to take any possible precautions of the case. Not observing the rules reported on this manual can create dangerous situations. After receiving the unit, immediately check its integrity. The unit left the factory in perfect conditions; any eventual damage must be questioned to the carrier and recorded on the Delivery Note before it is signed. The company must be informed, within 8 days, of the extent of the damage. The Customer should prepare a written statement of any severe damage.

Before accepting the unit check:

- The unit did not suffer any damage during transport;
- The delivered goods are conforming to what shown in the delivery note.

In Case of Damage

- List the damage on the delivery note
- Inform the Company of the extent of the damage within 8 days of receipt of the goods. After this time any claim will not be considered.
- A full written report is required for cases of severe damage.

4.5 Storage

Units should be stored under cover and ideally, should remain in their packaging. The tools that are supplied for opening the electrics box should be formally transferred to the person responsible for the plant.

4.5.1 Shipment

The shipment must be carried out by authorised carriers and the characteristics of the vehicle used must be such as to avoid damaging the machinery transported/to be transported, neither during loading and unloading nor during transport. If the roads to be driven are irregular, the vehicle must be fitted with special suspensions or internal walls in order not to damage the unit during the shipment.



The maximum ambient temperature for storage/shipment is +45°C and the minimum is -20°C,

4.6 Unpacking



Packaging could be dangerous for the operators.

It is advisable to leave packaged units during handling and remove it before the installation.

The packaging must be removed carefully to prevent any possible damage to the machine.

The materials constituting the packaging may be different in nature (wood, cardboard, nylon, etc.).



The packaging materials should be separated and sent for disposal or possible recycling to specialist waste companies.

4.7 Lifting and handling

When unloading the unit, it is highly recommended to avoid any sudden move in order to protect refrigerant circuit, copper tubes or any other unit component. Units can be lifted by using a forklift or, in alternative, using belts, being sure that the method of lifting does not damage the lateral panels and the cover. It is important to keep the unit horizontal at all time to avoid damages to the internal components.

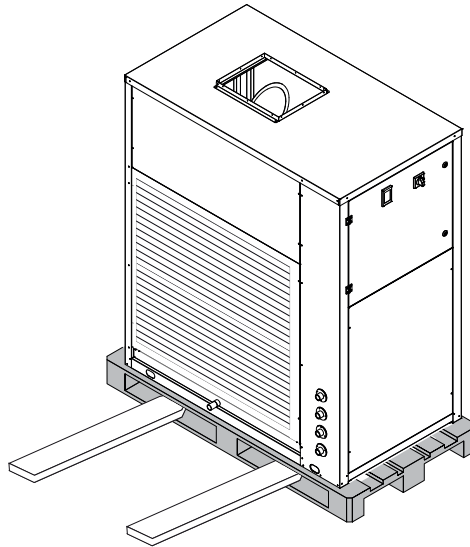

4.8 Location and minimum technical clearances



The unit has to be installed such that maintenance and repair is possible. The warranty does not cover costs for the provision of lifting apparatus, platforms or other lifting systems required to perform repairs during warranty period.



The installation site should be chosen in accordance with EN 378-1 and 378-3 standards. When choosing the installation site, all risks caused by accidental refrigerant leakage should be taken into consideration.

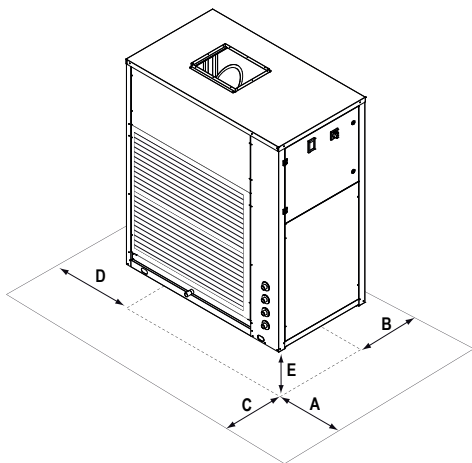

Mod.	A	B	C	D	E
270	500	500	700	500	200
350	500	500	700	500	200
450	500	500	700	500	200
550	500	500	700	500	200
750	500	500	700	500	200
950	500	500	700	500	200

4.8.1 Unit installation

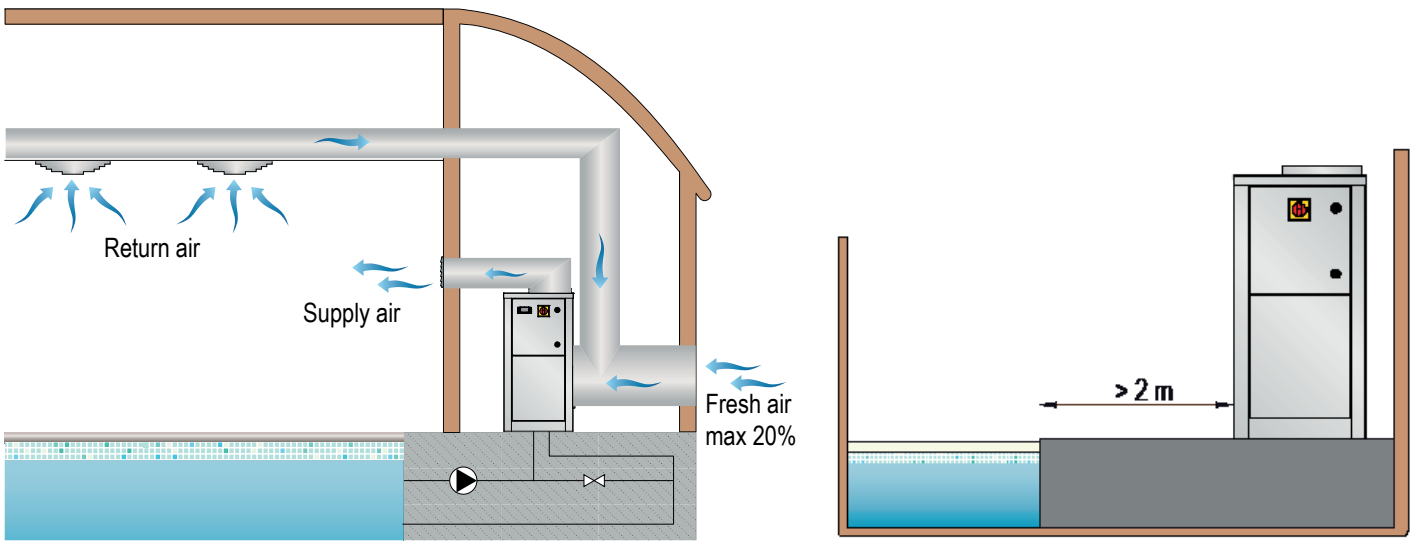

In the main european markets, the minimum distance of electric appliances from water sources (basins, showers, pools, whirlpools) is 2 meters! Before the installation of the unit it is compulsory to check the national or local norms.

4.9 Condensate draining connections

Condensate draining should be done using a flexible rubber pipe (about 1mt. long). On the condensate discharge pipe it must be installed a syphon with a minimum height equal to the suction pressure of the fan.

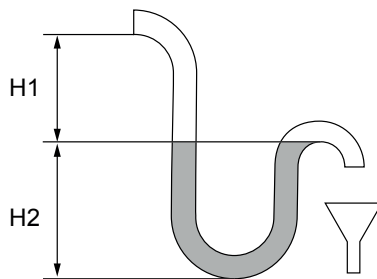
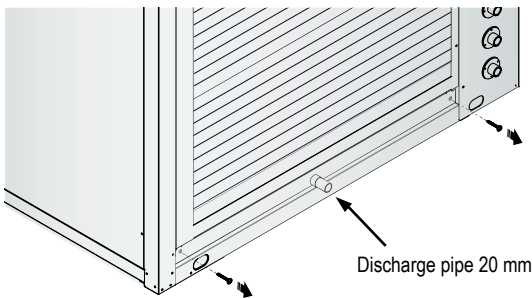

$H1 = 20 \text{ mm}$
 $H2 = \Delta P / 2 + 20 \text{ mm}$
 ΔP = pressure difference inside the unit in mm water column
 $10 \text{ Pa} \approx 1 \text{ mm water column}$



The condensate drain line should have a water trap which may have minimum flying height equal to the suction of the fan, in any case never less than 35 mm.

4.9.1 How to remove the drip tray

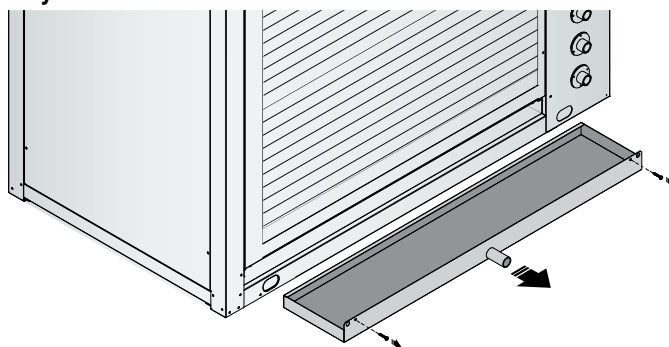

4.10 How to connect the hot water coil (HOWA) + 3 way modulating valve (KIVM) (Accessory)

To install the hot water coil it is necessary to remove the pre-knock out holes on the back panel of the unit; fix the water coil connections to the hot water coil. The hot water coil connections are 1".

The modulating 3 way valve is installed directly in factory as showed in the picture. It is controlled directly by the board.

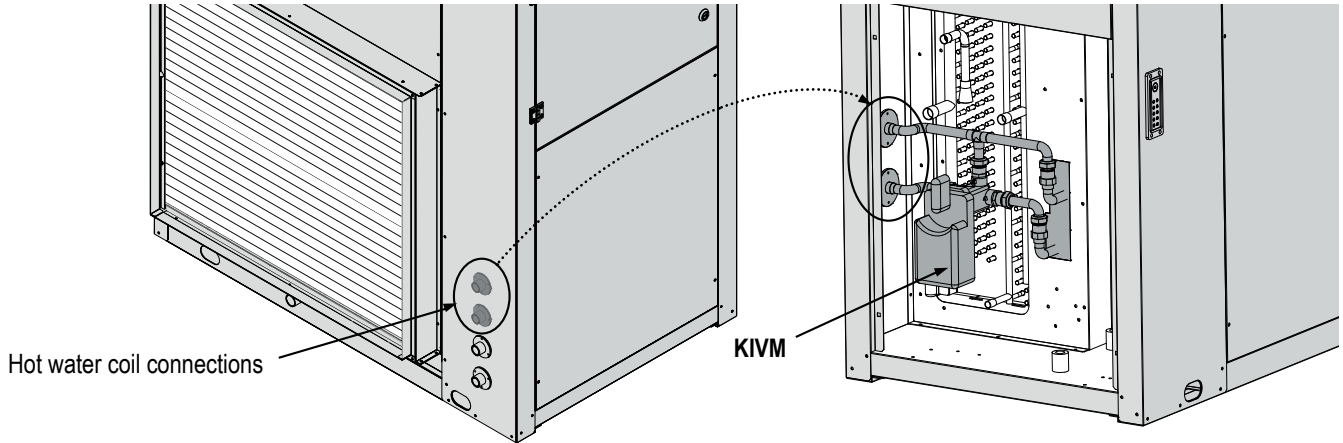

For proper equipment operation, it is recommended powering the unit with a dedicated pump. It is strongly recommended to connect the unit upstream of the collector system to ensure proper water supply (see drawing).



For a correct functioning of the unit, it's advisable to bleed carefully the circuit using the vent valve present in the unit.



The inlet maximum water temperature allowed is 80°C.
The inlet minimum water temperature allowed is 55°C.



This option is available only in combination with the electronic probe RGDD. It is not available in combination with remote mechanical hygostat.

4.11 How to remove filters

Remove the fixing metallic frame and slide off the air filter as shown below.

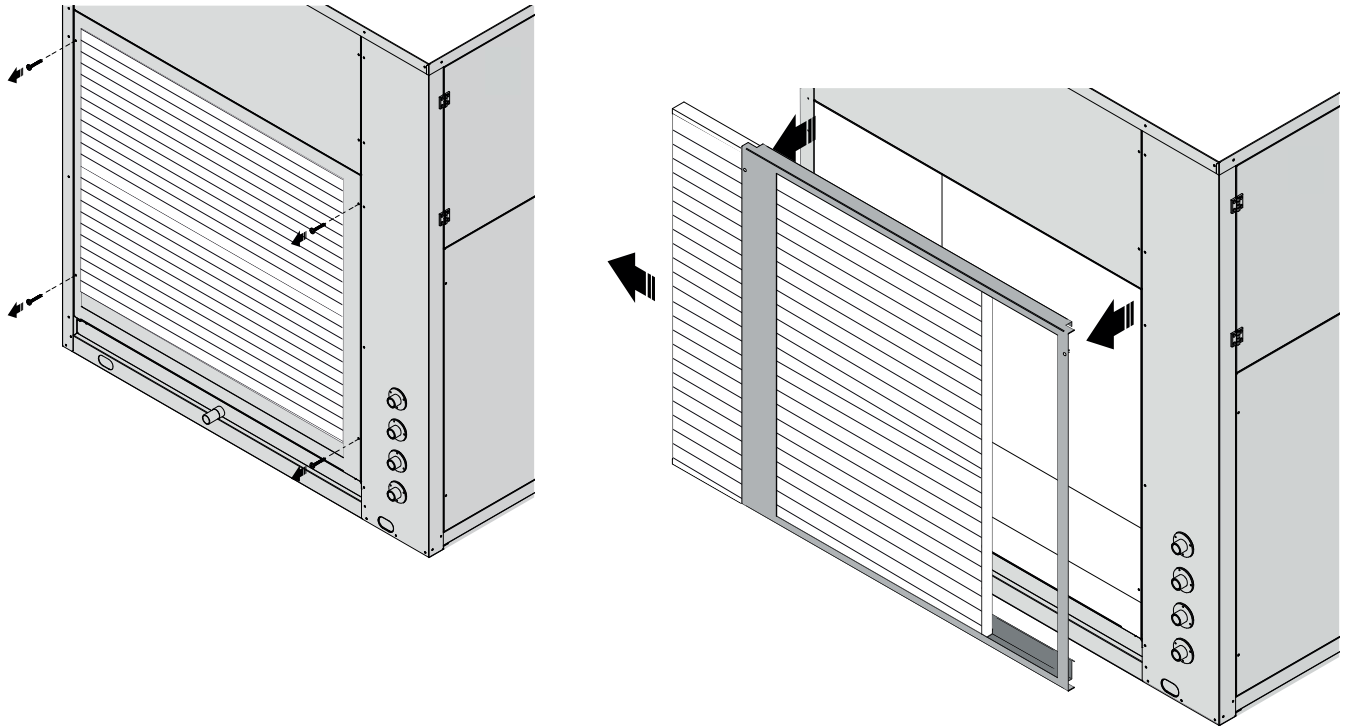

4.11.2 How to remove filter with accessory FARC

In case the unit is supplied with FARC (frame for ducted installation) slide off the air filter as shown below.

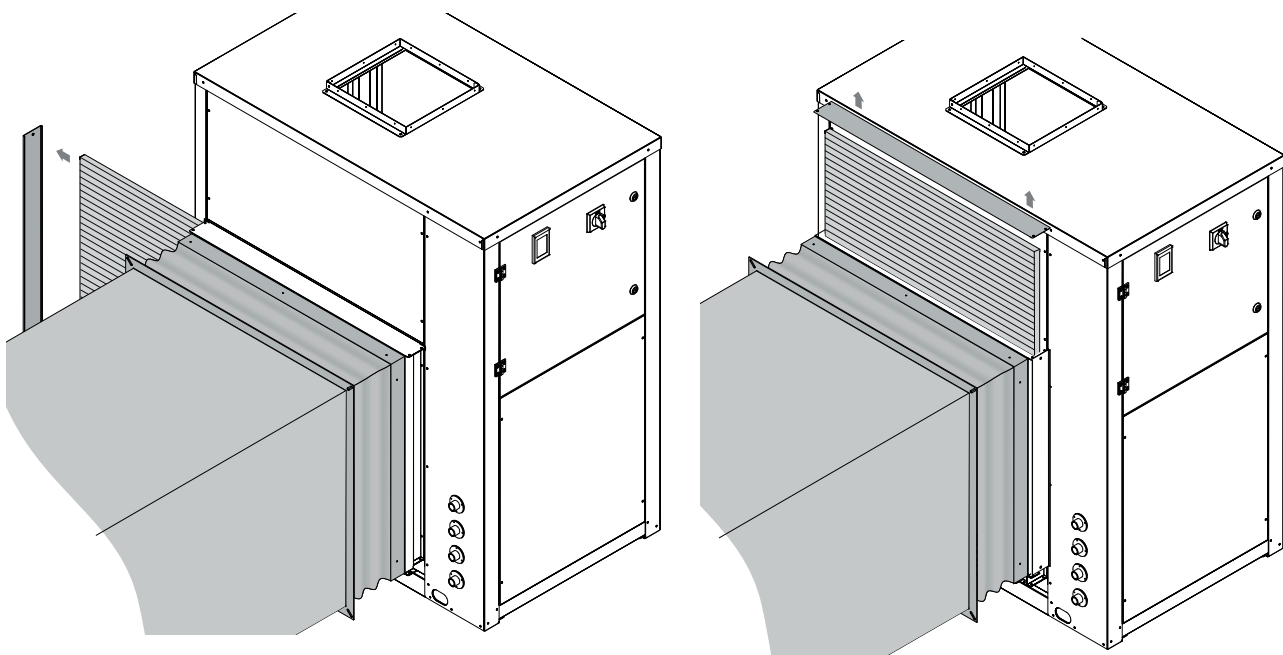

4.12 Desuperheater connection (RP01)

The desuperheater is factory fitted. It is controlled by a circulation pump (not supplied) directly managed by the control card.

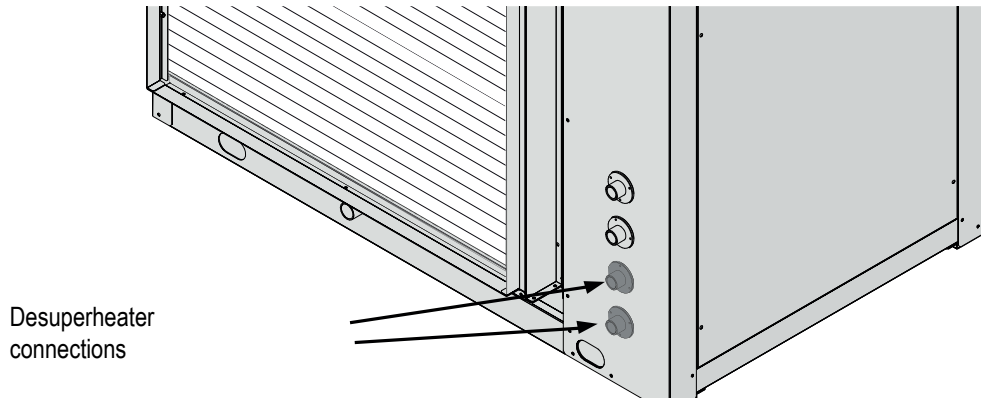

4.12.1 Partial heat recovery hydraulic connections (option)



The partial heat recovery coil must always be installed downstream of the water filter and upstream of the water disinfection treatment in the pools hydraulic circuit. The positioning of the heat exchanger upstream of the disinfection treatment is important because prolonged exposure to high concentrations of disinfectants chemicals can cause irreparable damage to the heat recovery coil. Downstream of the disinfection system has generally much higher concentration of disinfectants than in the pool. It's also important for the partial heat recovery coil to be positioned upstream of the filter, so that any debris from the pool do not pass into the coil. Which can cause poor performance of the coil and damage!

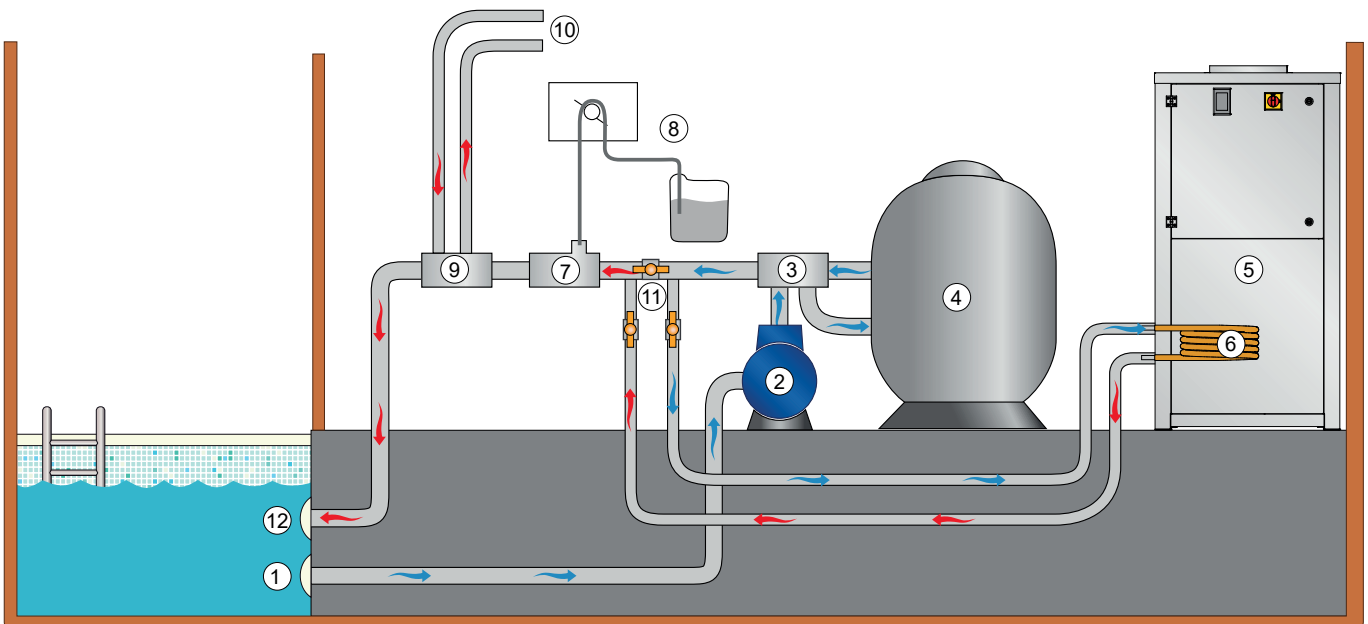

1	Water pool return	7	Pool water disinfection treatment
2	Pool water pump	8	Pool water disinfection dosing system
3	Pool water valve	9	Pool water heating system
4	Pool water filter	10	To the pool water heating system (Boiler, heat pump, etc.)
5	Dehumidifier	11	Pool water valves adjustment set
6	Partial heat recovery	12	Water pool supply

4.13 Installation of built-in room electronic sensor (RGDD)

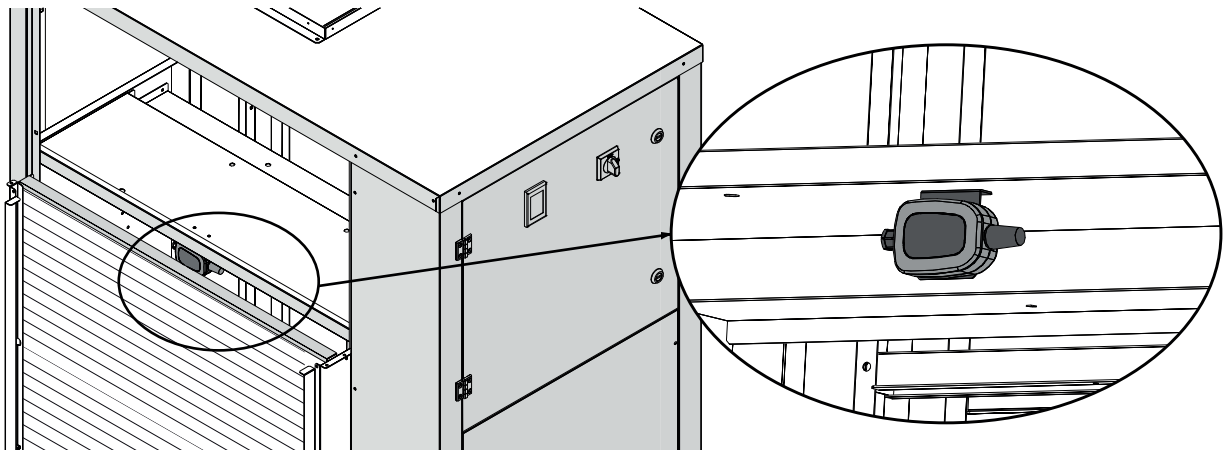

4.14 Serial interface card RS485 (INSE)

Supervision system interface serial board (MODBUS RS485 available only) The installation of the card will allow the unit to be plugged in and connected to a system with MODBUS protocol. This system allows you to remotely monitor all parameters of the unit and change their values. The serial interface board is normally fitted at the factory, where it is provided separately is necessary to respect the polarity of the wiring as shown in the diagram. Any reversal of polarity will result in the non-functioning unit.

The supervision connectivity cable must be telephone one type 2x0, 25 mm².

The unit is configured at the factory with serial address 1. In case of using the MODBUS system, you can request the list of variables by contacting the assistance.

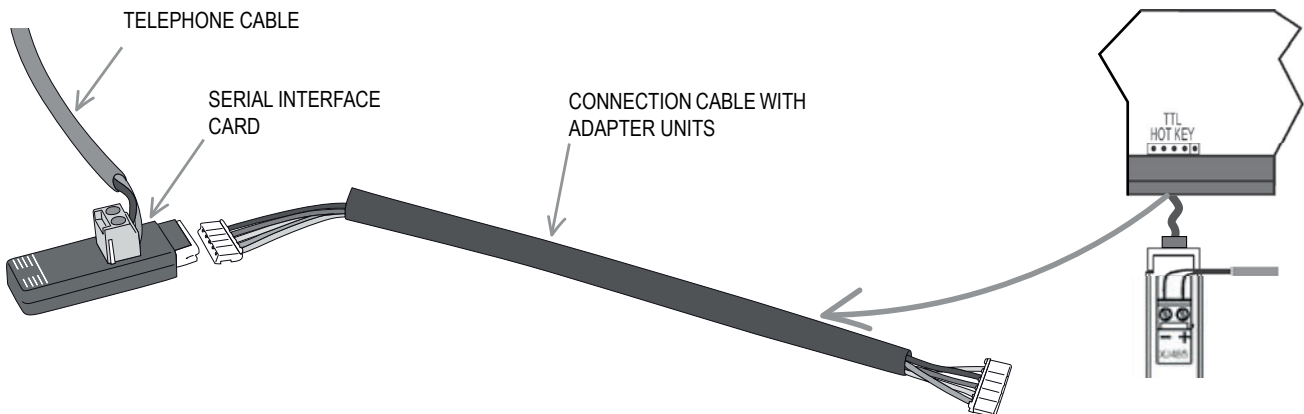

4.15 Connecting the unit to air duct channels

Units can be connected to air ducts channels either form the return and supply side.

4.15.1 Supply duct connection



In order to enable the proper functioning of the unit is important to ensure a constant air flow to the unit close to the nominal stated value. The maximum deviation allowed is 10%.



In order to limit the noise, it is necessary that the air speed inside ducts would never exceed 4 m / sec. With crossing high speed, it greatly reduces the dehumidification capacity of the unit and increases the risk of dragging of water condensation in the air ducts with a potential damage to the furniture and / or flooring.



It is always recommended to use a flexible connection between the unit and air distribution system (duct channel) in order to reduce the transmission of vibrations

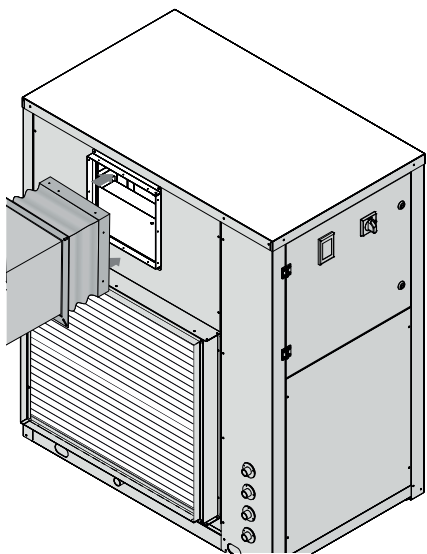

ASLE
Left hand side Supply

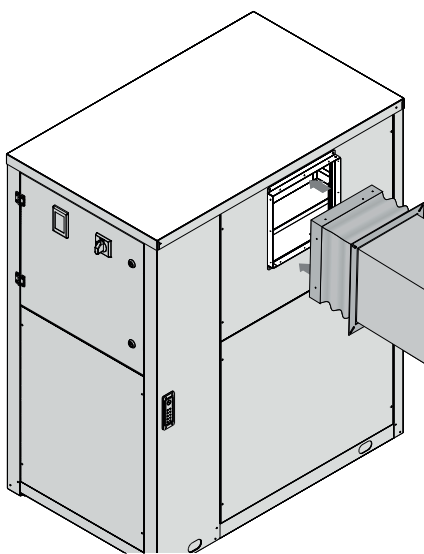

ASRI
Right hand side Supply

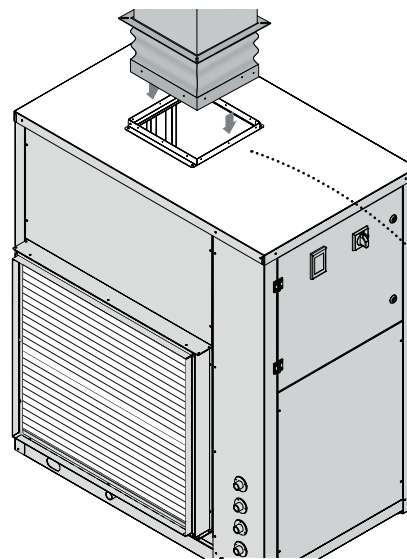

ASVE
Vertical Supply (standard)

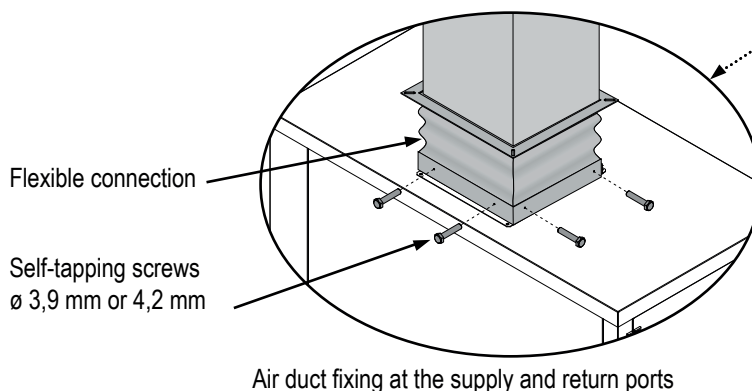

4.15.2 Return duct connection with FARC option

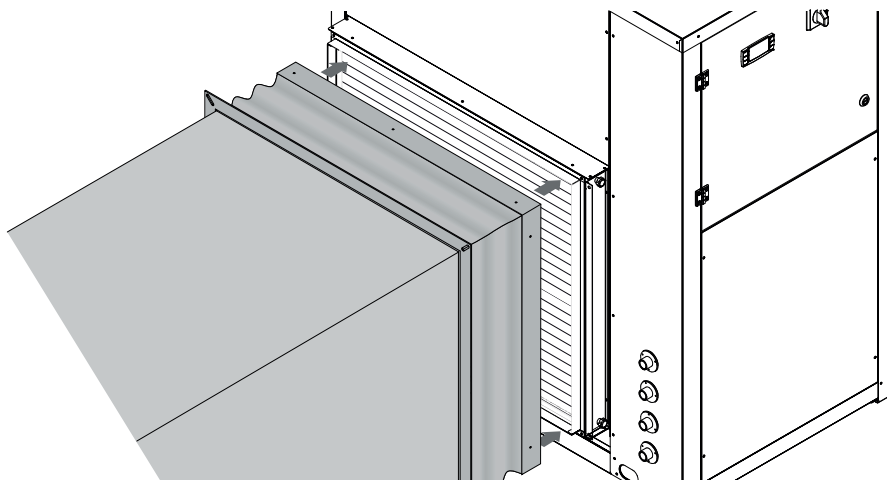

In case of return duct installation it is necessary the use of accessory FARC, a metallic frame that allow the slide off the air filter laterally.

4.16 Fan positioning

In all units the supply fan can be oriented in 3 different directions. The operation has to be carried out exclusively in the factory. Standard configuration is with vertical air discharge.

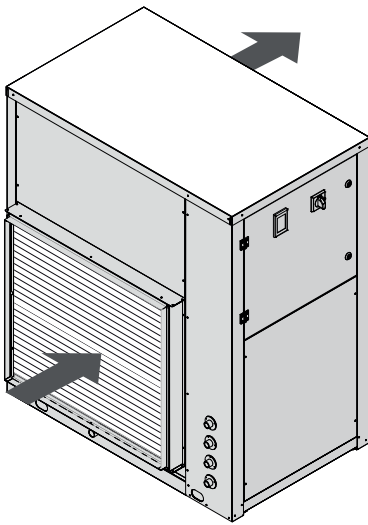

ASRI
Right hand side Supply

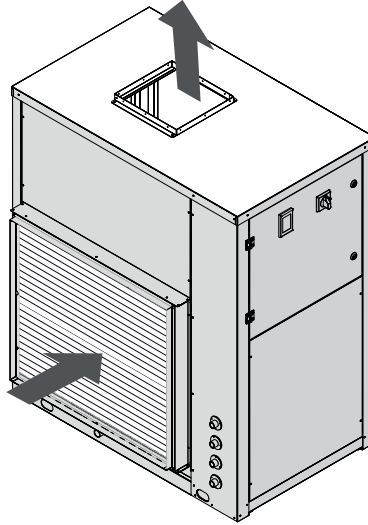

ASVE
Vertical Supply (standard)

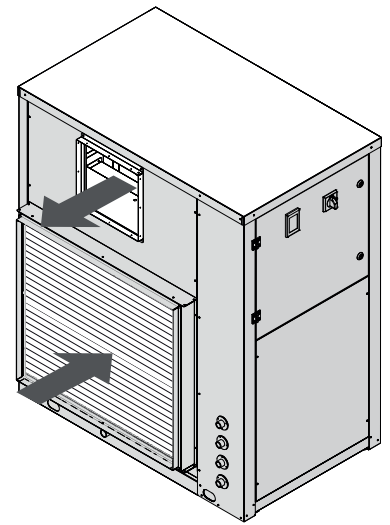

ASLE
Left hand side Supply

4.17 Remote mechanical hygostat installation (HYGR)

The remote mechanical humidistat (HYGR) must be installed in the room to be treated at 1.2 - 1.5 m above the floor (wall mounted) in a position such as not receive external irradiations or air drafts. It should be noted that the values in the numbered scale identify the desired room relative humidity (%).

The humidistat is supplied separately. For connection please refer to the wiring diagram supplied along with the unit.

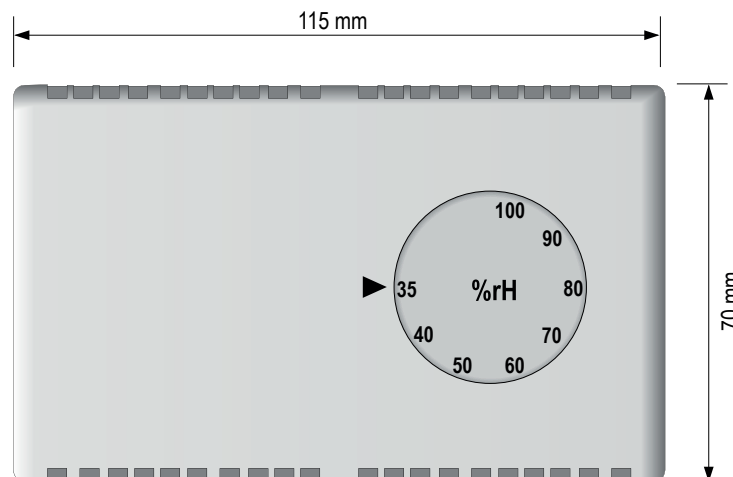



If humidistat or thermohygrostate is used, make sure that it can guarantee a correct reading of humidity and temperature in the environment and that this reading is similar to that in suction side. Under no circumstances can the sensor be placed in an ambient different from the unit's suction, nor can it be installed in areas where air flow is hampered.



To ensure a proper reading of temperature and humidity make sure that the device is not near hot or cold air flows or behind curtains or other obstacles.

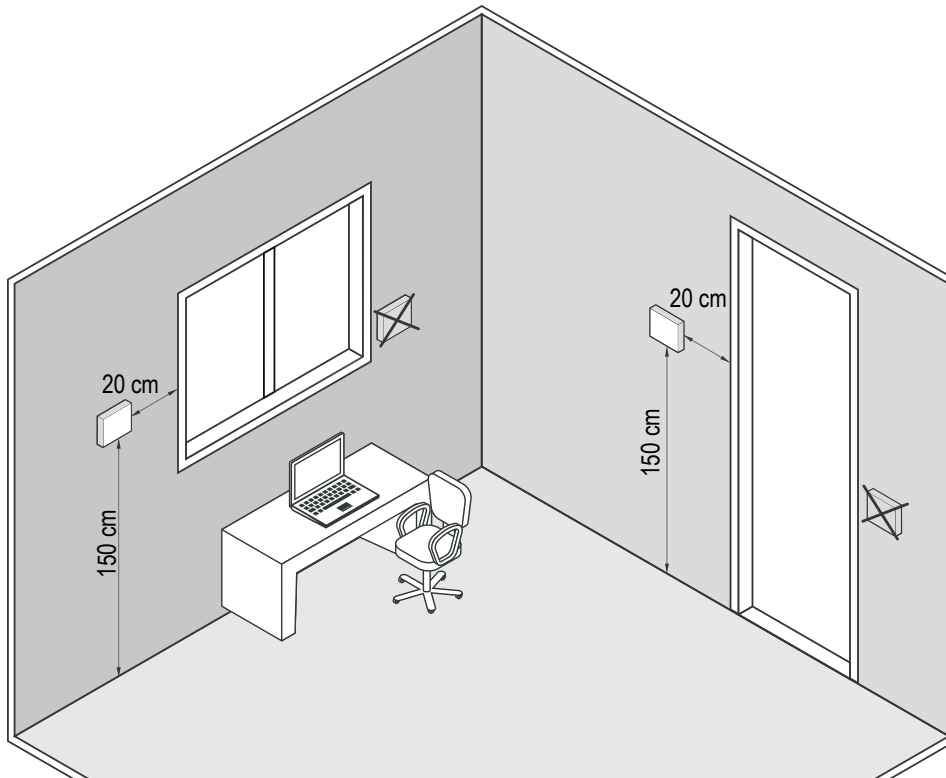

4.18 Electric connections: preliminary safety information

The electric panel is located inside the unit at the top of the technical compartment where the various components of the refrigerant circuit are also to be found. To access the electrical board, remove the front panel of the unit:



Power connections must be made in accordance to the wiring diagram enclosed with the unit and in accordance to the norms in force.



Make sure the power supply upstream of the unit is (blocked with a switch). Check that the main switch handle is padlocked and it is applied on the handle a visible sign of warning not to operate.



It must be verified that electric supply is corresponding to the unit electric nominal data (tension, phases, frequency) reported on the label in the front panel of the unit.



Power cable and line protection must be sized according to the specification reported on the form of the wiring diagram enclosed with the unit.



The cable section must be commensurate with the calibration of the system-side protection and must take into account all the factors that may influence (temperature, type of insulation, length, etc.).



Power supply must respect the reported tolerances and limits: If those tolerances should not be respected, the warranty will be invalidated.



Flow switches must be connected following the indication reported in the wiring diagram. Never bridge flow switches connections in the terminal board. Guarantee will be invalidated if connections are altered or not properly made.



Make all connections to ground provided by law and legislation.



Before any service operation on the unit, be sure that the electric supply is disconnected.



The power line and the unit external safety devices must be sized in order to ensure the correct voltage at the maximum operating conditions of the unit reported in the wiring diagram of the unit.



FROST PROTECTION

If opened, the main switch cuts the power off to any electric heater and antifreeze device supplied with the unit, including the compressor crankcase heaters. The main switch should only be disconnected for cleaning, maintenance or unit repair.

4.19 Electrical data



The electrical data reported below refer to the standard unit without accessories. In all other cases refer to the data reported in the attached electrical wiring diagrams.



The line voltage fluctuations can not be more than $\pm 10\%$ of the nominal value, while the voltage unbalance between one phase and another can not exceed 1%, according to EN60204. If those tolerances should not be respected, please contact our Company.

Model		270	350	450	550	750	950
Power supply	V/~/Hz	400/3+N/50	400/3+N/50	400/3+N/50	400/3+N/50	400/3+N/50	400/3+N/50
Control board	V/~/Hz	24	24	24	24	24	24
Auxiliary circuit	V/~/Hz	230/1/50	230/1/50	230/1/50	230/1/50	230/1/50	230/1/50
Fans power supply	V/~/Hz	400/3/50	400/3/50	400/3/50	400/3/50	400/3/50	400/3/50
Line section	mm ²	6	6	6	25	25	25
PE section	mm ²	4	4	4	16	16	16
Line section⁽¹⁾	mm ²	16	16	16	35	35	35
PE section⁽¹⁾	mm ²	10	10	10	25	25	25

(1) The data refer to the unit with electric heaters (HOEL)



Electric data may change for updating without notice. It is therefore necessary to refer always to the wiring diagram present in the units.

4.20 How to connect the power supply

For powering the unit remove the front panel; use the appropriate fairlead present in the side panel and connect the power cord to the terminal block in the cabinet. After connecting all cable carefully close the front panel.

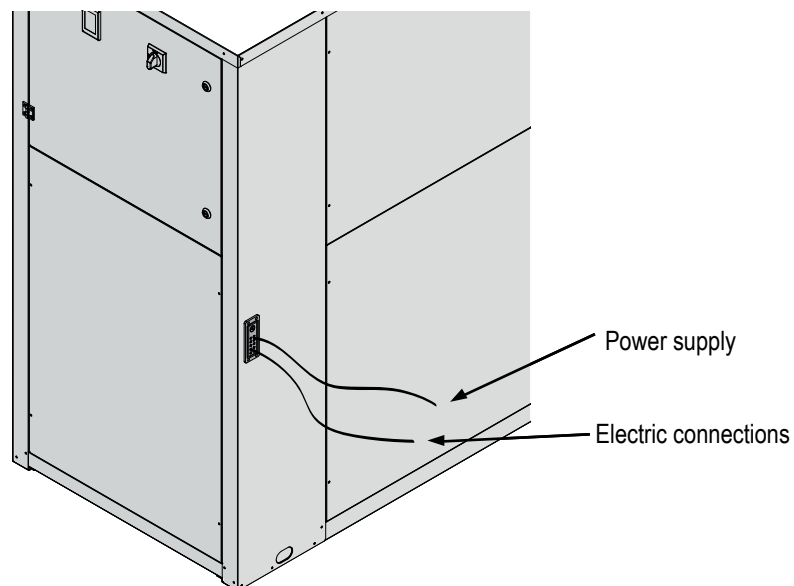

4.21 Electric connections



The numbering of the terminals may change without notice. For their connection is mandatory to refer to the wiring diagram supplied along with the unit.

4.21.1 Remote wiring connections

All terminals referred to in the explanations below will be found on the terminal board inside the electrical box. All electric connections mentioned below have to be made by the installer, on site.



REMOTE ON / OFF

To switch the unit on or off from remote control.

Contacts are voltage free.

Le unità sono fornite di serie dalla fabbrica con morsetti ponticellati.

Contact closed, unit ON,

Contact open, unit OFF.

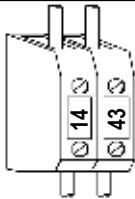

ROOM HYGROSTAT (UA)

(Only if remote mechanical hygostat (HYGR) is used)

Contact UA open: unit off.

Contact UA closed: unit in operation.

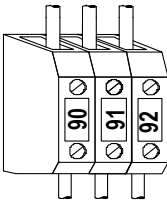

REMOTE GENERAL ALARM

For remote display of a general alarm, connect the visual or audible device between terminals 90-91-92.

Contacts 90/91 NC (Normally closed)

Contacts 91/92 NO (Normally opened)

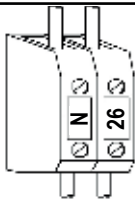

DESUPERHEATER PUMP

Is used to operate the pump of the desuperheater unit.

Contact 230 V, maximum current consumption 1A.

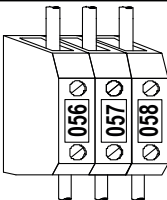

HOT WATER PUMP

It is used to manage the hot water pump in combination to the hot water coil built in the unit.

Dry contact, 230 V, maximum current consumption 1A.

Contacts 056/057 NC (Normally closed)

Contacts 057/058 NO (Normally open)

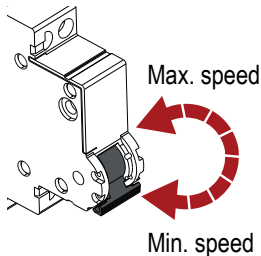

FAN SPEED

The fans are directly connected to the fan; they are all at 2 speeds, with integrated thermal protection.

4.22 Refrigerant circuit layout

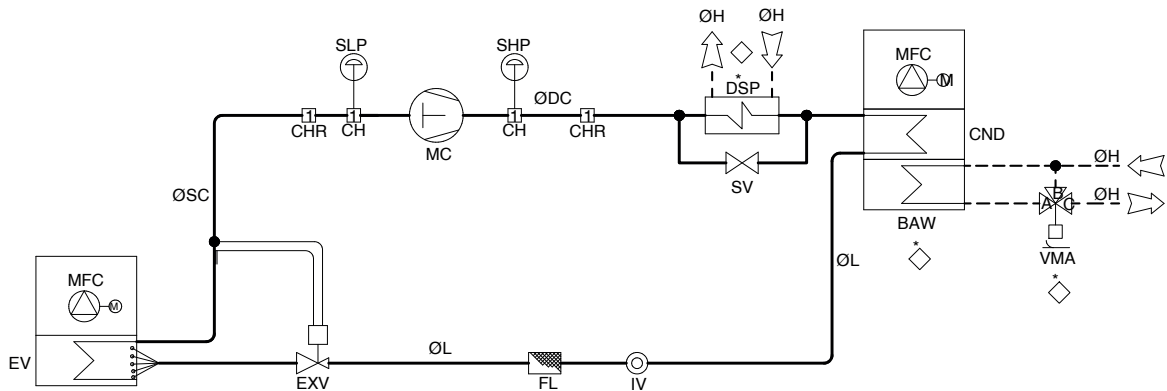

BAW	Water coil	IV	Moisture indicator sight glass
CH	Charging plug	MC	Compressor
CHR	Charging plug	MFC	Centrifugal fan
CND	Condenser	SHP	High pressure pressostat
DSP	Desuperheater	SLP	Low-high pressure switch
EV	Evaporator	SV	Shut off valve
EXV	Thermostatic valve	VMA	Water modulating valve
FL	Liquid line filter		



The cooling circuit principle diagram is purely indicative.

5. UNIT START UP

5.1 Preliminary checks

Before starting the unit the checks detailed in this manual of the electric supply and connections, the hydraulic system and the refrigerant circuit, should be performed.



Start-up operations must be performed in accordance with the instructions detailed in the previous paragraphs.

5.1.1 Before start-up



Damage can occur during shipment or installation. It is recommended that a detailed check is made, before the installation of the unit, for possible refrigerant leakages caused by breakage of capillaries, pressure switch connections, tampering of the refrigerant pipework, vibration during transport or general abuse suffered by the unit.

- Verify that the unit is installed in a workmanlike manner and in accordance with the guidelines in this manual.
- Check that all power cables are properly connected and all terminals are correctly fixed.
- The operating voltage the one shown on the unit labels.
- Check that the unit is connected to the system earth.
- Check that there is no refrigerant leakage.
- Check for oil stains, sign of a possible leak.
- Check that the refrigerant circuit shows the correct standing pressure on the pressure gauges (if present) otherwise use external ones.
- Check that the Schrader port caps are the correct type and are tightly closed.
- Check that crankcase heaters are powered correctly (if present).
- Check that all water connections are properly installed and all indications on unit labels are observed.
- The system must be flushed, filled and vented in order to eliminate any air.
- Check that the water temperatures are within the operation limits reported in the manual.
- Before start up check that all panels are replaced in the proper position and locked with fastening screws.



Do not modify internal wiring of the unit as this will immediately invalidate the warranty.

5.2 Description of the control panel



5.2.1 Display icons

The instrument display is divided into three zones:

Left Zone: the display shows the icons,

Top right zone: the display shows room temperature.

Bottom right zone: the display shows room humidity.

Icon	Meaning	Icon	Meaning
	Not used.		Not used.
	Compressors 1 and 2.		Not used.
	Dehumidification.	HP	High Pressure.
	Not used.		General Alarm.
	Unit fan.	Vset	Not used.
	On if the unit is turned on.	menu	Function menu active.
	Electric heater or water valve activated.	Flow!	Not used.

5.2.2 Key function



M Press and release: makes it possible to enter the functions menu.



SET Press and release in the main display:

makes it possible to display the set points;

Humidity set, in the bottom line will appear the label **SETI**.

Temperature set, in the bottom line will appear the label **SETH**.

Press for 3 seconds and release in the main display:

makes it possible to modify the set points;



In standard mode, with electronic sensor installed, allows the display of the following icons:

1 click: The bottom line displays **Tamb**: room temperature.

2 clicks: The bottom line displays **rH**: room humidity.

In standard mode with mechanical thermostat/hygrostat, allows the display of the following icons:

the top line displays the label **TOn** (room temperature request) or **TOff** (room temperature in set).

the bottom line displays the label **UOn** (room humidity request) or **UOff** (room humidity in set).

In programming mode it allows the user to scroll through parameter codes or to change values.



In standard mode allows the display of the different temperatures in opposite way of the above arrow.

In programming mode allows to scroll through the parameter codes or increases the values



If pressed down for 5 seconds, it makes it possible to switch the unit on or off.

5.3 Remote control panel



5.3.1 Display icons

The instrument display is divided into three zones:

Left Zone: the display shows the icons,

Top right zone: the display shows ambient temperature.

Bottom right zone: the display shows ambient humidity.

Icon	Meaning	Icon	Meaning
	Not used.		Not used.
	Compressors 1 and 2.		Not used.
	Dehumidification.		High Pressure.
	Not used.		General Alarm.
	Unit fan.		Not used.
	On if the unit is turned on.		Function menu active.
	Electric heater or water valve activated.		Not used.

5.3.2 Key functions

M Press and release: makes it possible to enter the functions menu

SET Press and release in the main display:

makes it possible to display the set points;

Humidity set, in the bottom line will appear the label **SETI**.

Temperature set, in the bottom line will appear the label **SETH**.

Press for 3 seconds and release in the main display:

makes it possible to modify the set points;

In standard mode, with electronic sensor installed, allows the display of the following icons:

1 click: The bottom line displays **Tamb**: room temperature.

2 clicks: The bottom line displays **rH**: room humidity.



In standard mode with mechanical thermostat/hygrostat, allows the display of the following icons:
the top line displays the label **TOn** (room temperature request) or **TOff** (room temperature in set).
the bottom line displays the label **UOn** (room humidity request) or **UOff** (room humidity in set).

In programming mode it allows the user to scroll through parameter codes or to change values.



In standard mode allows the display of the different temperatures in opposite way of the above arrow.

In programming mode allows to scroll through the parameter codes or increases the values

If pressed down for 5 seconds, it makes it possible to switch the unit on or off.

6. USE

6.1 Switch the unit on

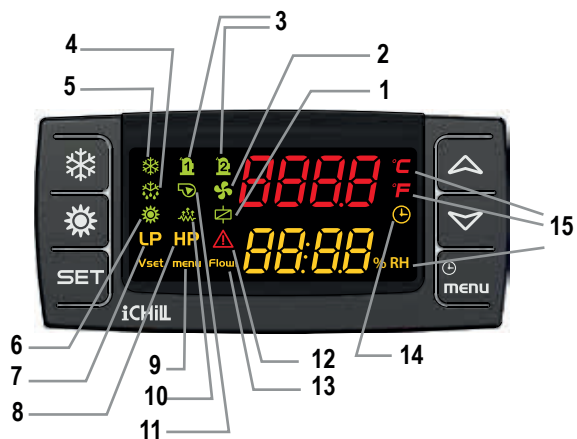

Legend

1	Not used.	9	Icon ON: function menu active.
2	Icon ON: if fans are running.	10	Icon ON: Electric heater or water valve activated.
3	Icon ON: if the compressor is turned on; Icon blinking: if the compressor is the ignition timing.	11	Not used.
4	Icon ON: Dehumidification cycle activated.	12	Icon blinking on alarm.
5	Not used.	13	Not used.
6	Icon ON: the unit is on.	14	Counter between two defrost cycles.
7	Not used.	15	Icon ON: the display shows the room temperature or humidity.
8	Icon blinking: high pressure alarm is active.		

In order to power the unit, turn the main switch to the ON position.

a. In case of electronic sensor the display shows room temperature (in the top line) e room humidity (in the bottom line).

b. In case of remote mechanical thermostat/hygrostat the display shows tOFF/UOFF (temperature/humidity off, unit in set) or tOn/UOn (temperature/humidity on, unit running).



Push 5 seconds the key  to start the unit.

6.1.2 Display during operation

Defrost

Unit equipped with electronic sensor



Defrost

Unit equipped with mechanical thermostat/hygrostat



Unit in drip time after defrost

Unit equipped with electronic sensor



Unit in drip time after defrost

Unit equipped with mechanical thermostat/hygrostat



6.2 Stop

to stop the unit press the key  for 5 seconds. The unit goes into stand-by mode.

6.3 Stand-by

When the unit is switched off from keyboard or remote control panel, it goes into stand-by mode. In this mode the microprocessor control displays the sensor readings and is also able to manage alarm situations. The only visible labels on the display are the temperature and the humidity (in case of unit equipped with electronic sensor), or OFF (in case of unit equipped with mechanical thermostat/hygrostat). In case the unit is switch off from the remote ON/OFF contact, the display shows OFF.

Display in stand-by mode.



Display in OFF from remote contact.



6.4 How to change the set points







When modifying or varying the machine's operating parameters, make sure that you do not create situations that conflict with the other set parameters.

Select the required set point pressing the  key. The label appears at the bottom of the display:

SEtI Room humidity set point;

SEtH Room temperature set point.

To set the required set-points press again the  for 3 seconds. The current value flashes at the top and can be modified using the  ,  keys we can modify the parameter. Then press the  key to memorise the parameter and exit.



All set points are intended as room conditions.

6.4.1 Adjustable parameters

The adjustable set points that can be modified by the end user are:

Label	Function	Adjustment limit	Default value
SEt I	Room humidity set point	40÷90%	50%
SEt H	Room temperature set point	18÷30°C	26°C
PAS	Password	(Contact the Company)	



The units are supplied with a very sophisticated control system with many other parameters that are not adjustable by the end user; these parameters are protected by a manufacturer password.

6.5 Acoustic signal silencing

Pressing and releasing one of the keys; the buzzer is switched off, even if the alarm condition remains in place.



6.6 Display during alarm



In case of alarm the display shows:

-  + alarm code in the bottom line, (the bottom line of the display shows the alarm code in alternatively to the standard label).

6.7 Alarm reset

Press the  key (the menu **AlrM** appears at the bottom right of the display). Press the  key to display the alarm event.

In case of multiple alarms, use the ,  keys to scroll the list of the active alarms.

There are two types of alarms:

Reset alarms:

RST label appears on the upper part of the display. In this case press the  key to reset.

Non reset alarms:

The **nO** label appears on the upper part of the display. In this case the alarm is permanent; contact the Company.

7. MAINTENANCE OF THE UNIT

7.1 General warnings



Starting from 01/01/2016 the new European Regulation 517_2014, "Obligations concerning the containment, use, recovery and destruction of fluorinated greenhouse gases used in stationary refrigeration, air conditioning and heat pumps", became effective. This unit is subject to the following regulatory obligations, which have to be fulfilled by all owners, operators and technical staff:

- (a) Keeping the equipment records
- (b) Correct installation, maintenance and repair of equipment
- (c) Leakage control
- (d) Refrigerant recovery and disposal management
- (e) Presentation to the Ministry of the Environment of the annual declaration concerning the atmospheric emissions of fluorinated greenhouse gases.

Maintenance can:

- Keep the equipment operating efficiently
- Prevent failures
- Increase the equipment life



It is advisable to maintain a record book for the unit which details all operations performed on the unit as this will facilitate troubleshooting.



Maintenance must be performed in compliance with all requirements of the previous paragraphs.



Use personal protective equipment required by regulations as compressor casings and discharge pipes are at high temperatures. Coil fins are sharp and present a cutting hazard.



If the unit is not to be used during the winter period, the water contained in the pipes may freeze and cause serious damage. In this event, fully drain the water from the pipes, checking that all parts of the circuit are empty including any internal or external traps and siphons.



If it is necessary to replace a component of the machine, both for ordinary and extraordinary maintenance, this component must have the same or higher characteristics than those present. The same or higher performances or thicknesses are meant for the characteristics, which do not compromise the safety, the use, the handling, the storage, the pressures and the temperatures of use of the machine provided by the manufacturer.



The taps in the machine must always be in open position before starting. If it is necessary to disconnect the refrigeration circuit by closing the taps, it is necessary to take precautions to prevent the unit from starting up, even accidentally, and to indicate that the taps have been properly closed with special signs, both on the tap and in the electrical panel. In any case, the taps must remain closed as less as possible.

7.2 Drive access

Access to the unit once installed, should only be possible to authorized operators and technicians. The owner of the equipment is the company legal representative, entity or person owns the property where the machine is installed. They are fully responsible for all safety rules given in this manual and regulations.

7.3 Scheduled maintenance

The owner must make sure that the unit is periodically inspected, also on-site, adequately maintained, according to the type, size, age and use of the system, and to the indications contained in the Manual.

Servicing during the unit's operating lifetime and, in particular, scheduled leak detection, on-site inspections and check-ups of safety equipment, must be carried out as provided by local laws and regulations in force.



If leak detection instruments are installed on the system, they must be inspected at least once a year, to make sure that they work properly.

During its operating life, the unit shall be inspected and verified in accordance with applicable local laws and regulations. In particular, when there are no stricter specifications, the indications given in the following table (see EN 378-4, Annex D) must be followed, with reference to the situations described.

CASE	Visual Inspection	Pressure Test	Search for leaks
A	X	X	X
B	X	X	X
C	X		X
D	X		X

A	Inspection after an intervention with possible effects on the mechanical strength or after use change or in case the machine has not being working for more than two years. Replace all the components which are not suitable any more. Do not carry out checks at a higher pressure than the one indicated in the project.
B	Inspection after a repair, or significant adjustment of the system, or its components. The check may be limited to the interested parts, but if a leakage of refrigerant is detected, a leakage search must be carried out on the entire system.
C	Inspection after installation in a different position than the original one. Refer to point A when mechanical strength could have been affected by the change.
D	Leak search, following a well-founded suspicion of refrigerant leakage. It is recommended examined the system for leakage, either directly (use of leak detection systems) or indirectly (deduction of leakage based on analysis of operating parameters), focusing on the parts most prone to leakage (e.g. joints).



If a defect is detected that compromises the reliable operation of the unit, the unit cannot be re-started until it has been repaired.

7.4 Periodical checks



The start-up operations should be performed in compliance with all requirements of the previous paragraphs.



All of the operations described in this chapter **MUST BE PERFORMED BY TRAINED PERSONNEL ONLY**. Before commencing service work on the unit ensure that the electric supply is disconnected. The top case and discharge line of compressor are usually at high temperature. Care must be taken when working in their surroundings. Aluminium coil fins are very sharp and can cause serious wounds. Care must be taken when working in their surroundings. After servicing, replace the cover panels, fixing them with locking screws.

7.4.1 Instalación eléctrica y dispositivos de control

Operaciones a realizar	Periodicidad					
	Cada mes	Cada 2 meses	Cada 6 meses	Cada año	Cada 5 años	Según demanda
Verificar que la unidad funciona regularmente y que no haya presencia de alarmas	X					
Inspeccionar visualmente el equipo	X					
Verificar el ruido y las vibraciones de la unidad				X		
Verificar la funcionalidad de los dispositivos de seguridad y de los bloqueos				X		
Verificar las prestaciones de la unidad				X		
Verificar la potencia absorbida de los diferentes componentes (compresores, ventiladores,...)				X		
Verificar la tensión de alimentación de la unidad			X			
Verificar la fijación de los cables en sus respectivos borneros			X			
Verificar la integridad del revestimiento aislante de los cables eléctricos				X		
Verificar el estado y el funcionamiento de los contactores				X		
Verificar el funcionamiento del microprocesador y del display			X			
Limpiar los componentes eléctricos y electrónicos para evitar la acumulación de polvo				X		
Verificar el funcionamiento y la calibración de las sondas y de los trasductores				X		

7.4.2 Condensing coils and fans

Action to be performed	Frequency					
	Monthly	Every 2 months	Every 6 months	Every year	Every 5 years	As necessary
Visually inspect the coil	X					
Clean finned coils			X			
Check the water flow and/or any leaks (if HOWA is present)	X					
Clean the metal filter on the external water line ⁽²⁾ (if present)			X			
Check noise and vibration level of the fans				X		
Check the supply voltage of the fans			X			
Check the fans' electrical connections				X		
Check functioning and calibration of the fans' speed adjustment system (if present)				X		
Check air presence in the hydraulic circuit	X					
Check color of moisture indicator on liquid line				X		
Check for freon leaks ⁽¹⁾						X



⁽¹⁾ In order to carry out operations on the refrigerant, it is necessary to observe the European Regulation 517_2014, "Obligations regarding the containment, use, recovery and destruction of fluorinated greenhouse gases used in stationary refrigeration, air conditioning and heat pump equipment".



⁽²⁾ It can be carried out with a higher frequency (also weekly) depending on the Δt .

7.4.3 Compressors

Action to be performed	Frequency					
	Monthly	Every 2 months	Every 6 months	Every year	Every 5 years	As necessary
Visually inspect compressors				X		
Check noise and vibration level of the compressors				X		
Check the supply voltage of the compressors			X			
Check the compressors' electrical connections				X		
Check oil level in the compressors using the oil fill level indicator (if present)			X			
Check that the crankcase heaters are powered and working properly (if present)				X		
Check the conditions of the compressors' power cables and their tightness in the clamps			X			



Daily and monthly works may be carried out directly by the Owner of the system. All other works must be performed by authorised and trained personnel.



Any kind of cleaning whatsoever is forbidden before disconnecting the device from power supply by turning the master switch to the OFF position. It is forbidden to touch the device while barefooted or with wet or damp body parts.



Works on the cooling line must be carried out by qualified and trained technicians, as provided by local laws and regulations in force.



Before the start-up it is necessary to carry out all the operations described in the previous tables and make the necessary checks provided by the pre-start control module (valid for the Italian market) to be requested to the service.

7.5 Refrigerant circuit repair



If the refrigerant circuit is to be emptied, all the refrigerant must be recovered using the correct equipment by suitably qualified f-gas engineers.

For leak detection, the system should be charged with oxygen free nitrogen using a gas cylinder and suitable nitrogen pressure regulator, until 15 bar pressure is reached. Any leakage is detected using a bubble leak finder.



Never use oxygen instead of oxygen free nitrogen: explosions may occur.

Site assembled refrigerant circuits must be assembled and maintained carefully, in order to prevent malfunctions.

Therefore:

- Avoid oil replenishment with products that are different from that specified and that are pre-loaded into the compressor.
- In the event of a gas leakage on machines using refrigerant R410A even if it is only a partial leak, do not top up. The entire charge must be recovered, the leak repaired and a new refrigerant charge weighed in to the circuit.
- When replacing any part of the refrigerant circuit, do not leave it exposed for more than 15 minutes.
- It is important when replacing a compressor that the task be completed within the time specified above after removing the rubber sealing caps.
- When replacing the compressor following a burn out, it is advisable to wash the cooling system with appropriate products including a filter for acid.
- When under vacuum do not switch on the compressor.

8. DECOMMISSIONING

8.1 Disconnect the unit



All decommissioning operations must be performed by authorized personnel in accordance with the national legislation in force in the country where the unit is located.

- Avoid spills or leaks into the environment.
- Before disconnecting the machine please recover:
 - the refrigerant gas;
 - Glycol mixture in the hydraulic circuit;
 - the compressor lubricating oil.

Before decommissioning the machine can be stored outdoors, providing that it has the electrical box, refrigerant circuit and hydraulic circuit intact and closed.

8.2 Disposal, recovery and recycling

The frame and components, if unusable, should be taken apart and sorted by type, especially copper and aluminum that are present in large quantities in the machine.

All materials must be recovered or disposed in accordance with national regulations.



The refrigerant circuit of the unit contains lubricant oil that binds the disposal mode of components .

8.3 RAEE Directive (only UE)



The crossed-out bin symbol on the label indicates that the product complies with regulations on waste electrical and electronic equipment.
The abandonment of the equipment in the environment or its illegal disposal is punishable by law.

This product is included in the application of Directive 2012/19/EU on the management of waste electrical and electronic equipment (WEEE).

The unit should not be treated with household waste as it is made of different materials that can be recycled at the appropriate facilities. Inform through the municipal authority about the location of the ecological platforms that can receive the product for disposal and its subsequent proper recycling.

The product is not potentially dangerous for human health and the environment, as it does not contain dangerous substances as per Directive 2011/65/EU (RoHS), but if abandoned in the environment it has a negative impact on the ecosystem.

Read the instructions carefully before using the unit for the first time. It is recommended not to use the product for any purpose other than that for which it was designed, as there is a risk of electric shock if used improperly.

9. DIAGNOSIS AND TROUBLESHOOTING

9.1 Fault finding

All units are checked and tested at the factory before shipment, however, during operation an anomaly or failure can occur.



BE SURE TO RESET AN ALARM ONLY AFTER YOU HAVE REMOVED THE CAUSE OF THE FAULT; REPEATED RESET MAY RESULT IN IRREVOCABLE DAMAGE TO THE UNIT.

Code	Alarm description	Electronic sensor	mechanical thermostat/hygrostat	Cause	Solution
AhiP	High pressure	Yes	Yes	Too low airflow or high room temperature.	Check the filters, if necessary replace them. In ducted versions, check the pressure drop of the ducts.
AloP	Low pressure	Yes	Yes	Refrigerant charge leakage.	Contact the Company
APBa/ APBi	Room temperature probe sensor alarm PBa	Yes	No	Replace faulty sensor	Contact the Company
APBu	Room humidity probe sensor alarm PBU	Yes	No		
Atdf	Defrost time too long.	Yes	Yes	Warning	(Reporting only)
Atlo	Low room temperature.	Yes	No	Replace faulty sensor	Contact the Company
Athi	Hight room temperature.	Yes	No	Replace faulty sensor	Contact the Company
Atr	Electrical heater thermal alarm (if present)	Yes	Yes	Too low airflow	Check the filters, if necessary replace them. In ducted versions, check the pressure drop of the ducts.
Atc1	Compressor alarm	Yes	Yes	Compressor malfunctioning	Contact the Company

10. DIMENSIONAL DRAWINGS

DP 270 - 350 - 450

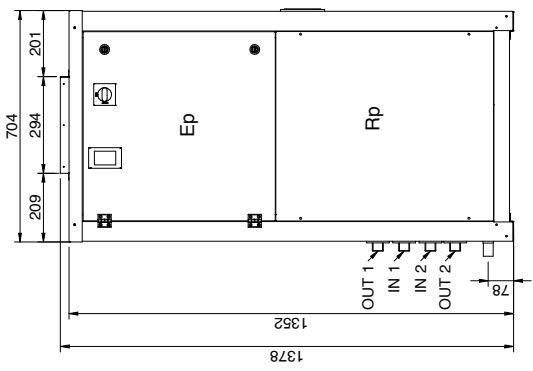
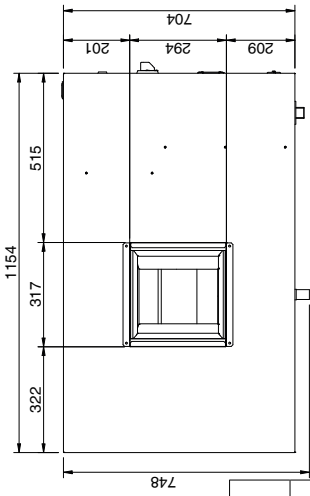
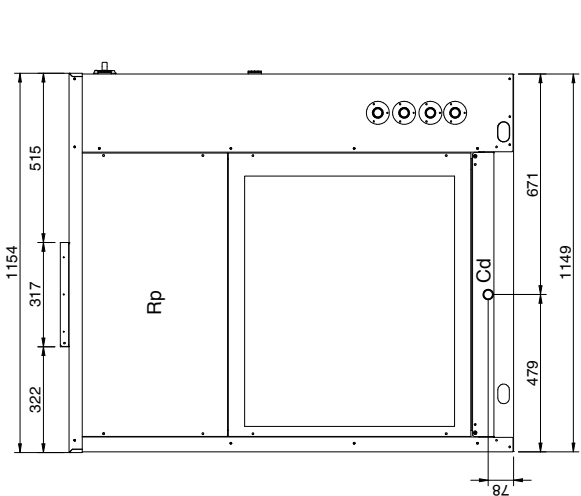
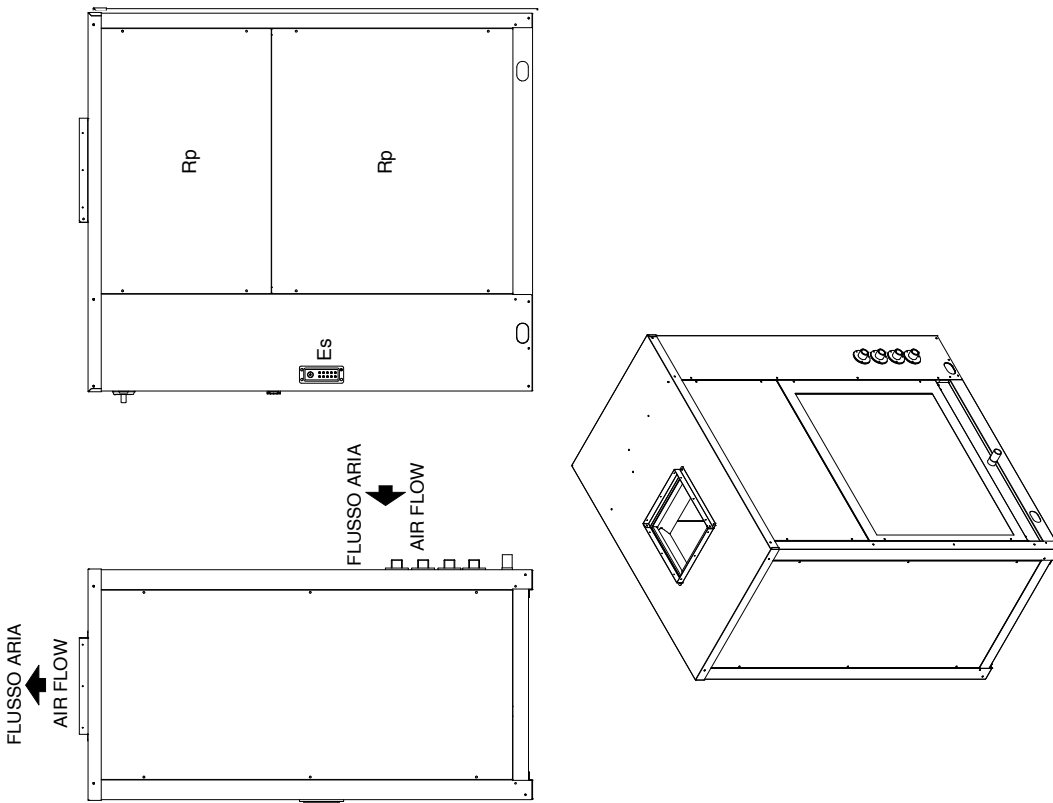

		Kg		
		DP 270	DP 350	DP 450
	Tot	207	211	215

Rp	REMOVABLE PANEL
Ep	ELECTRICAL PANEL
Es	POWER SUPPLY DRAIN INLET
Cd Ø 1"	CONDENSATE DRAIN
IN 1 Ø 1"	USER WATER INLET STANDARD
IN 2 Ø 1"	3 WAY WATER VALVE (OPTIONAL)
OUT 1 Ø 1"	USER WATER OUTLET STANDARD
IN 2 Ø 1"	USER WATER INLET DESUPERHEATER (OPTIONAL)
OUT 2 Ø 1"	USER WATER OUTLET DESUPERHEATER (OPTIONAL)

DP 270 - 350 - 450 (FARC)

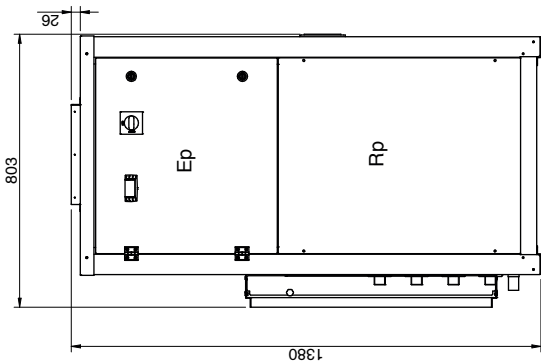
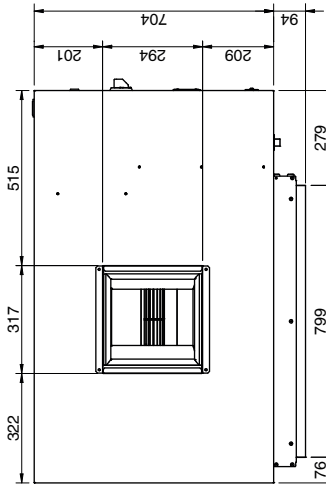
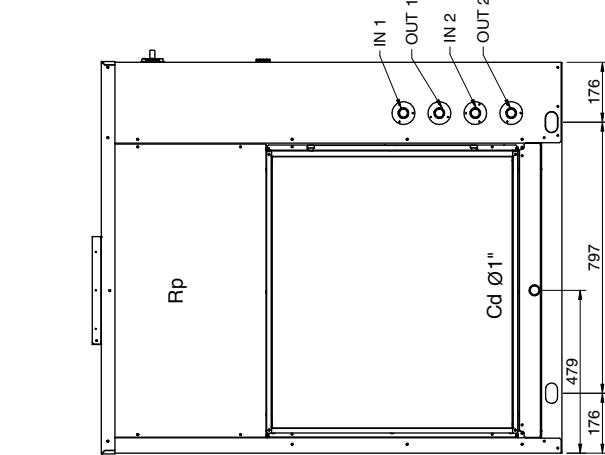
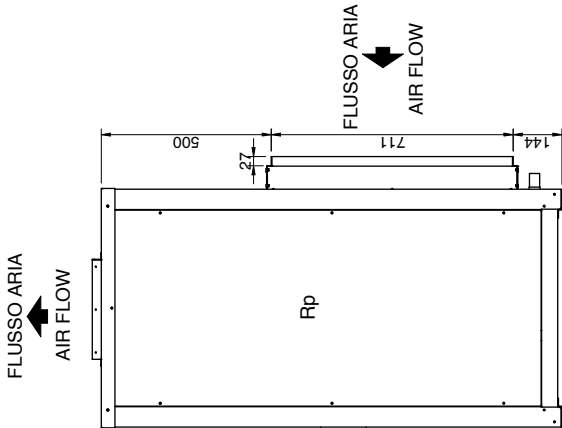
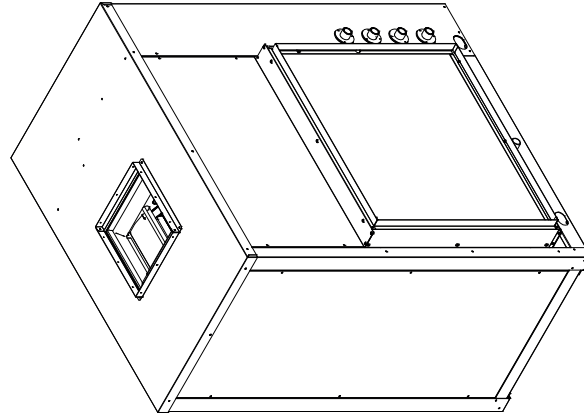
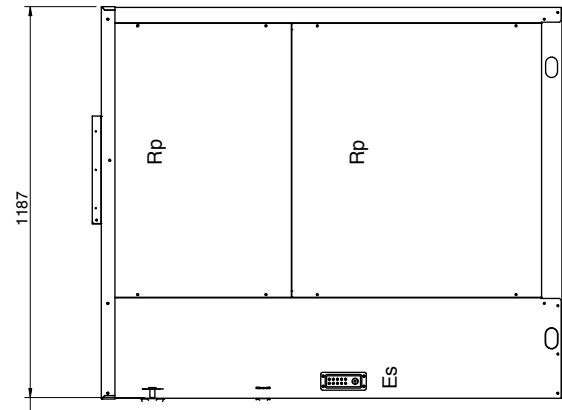

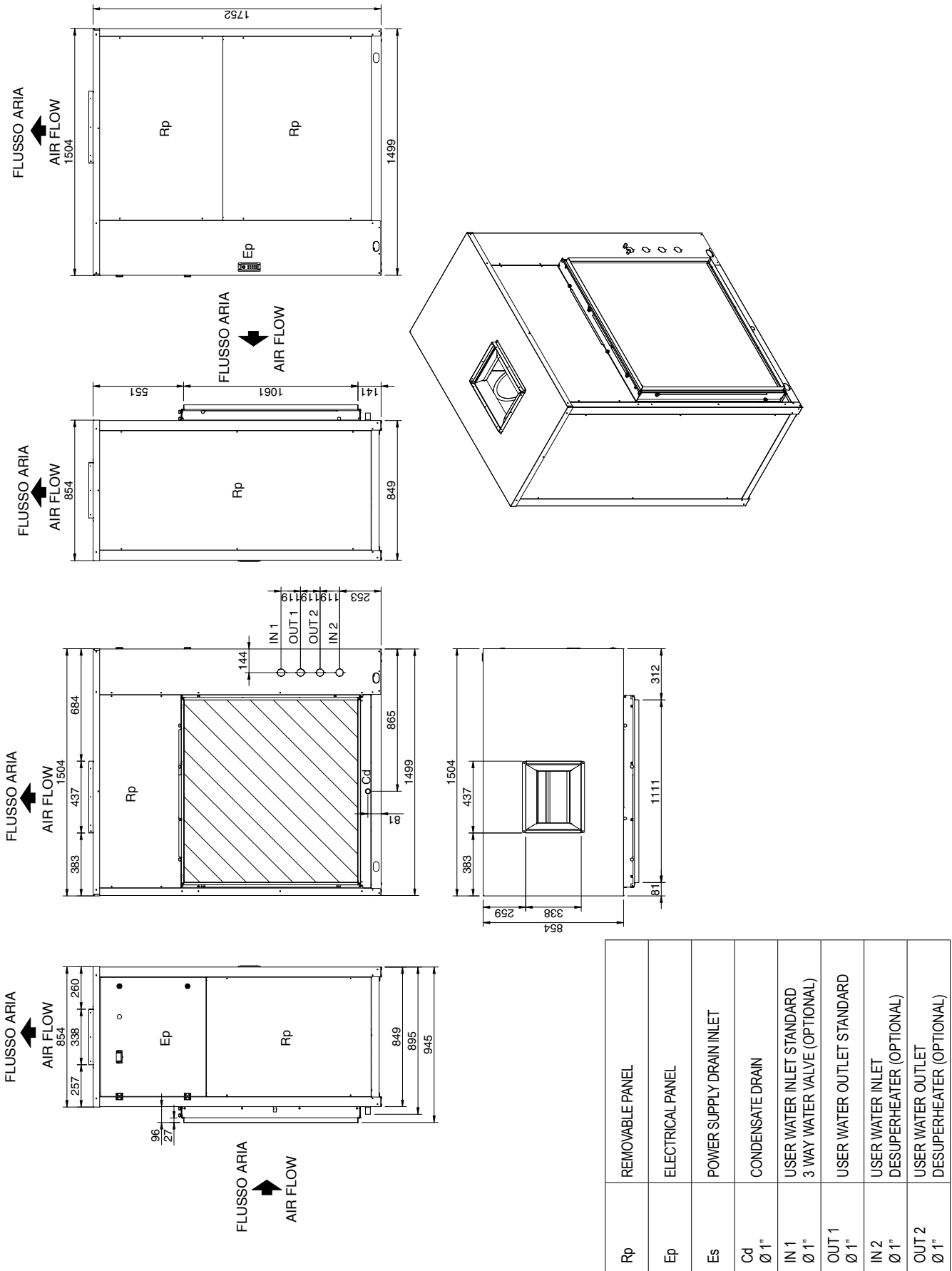

Rp	REMOVABLE PANEL
Ep	ELECTRICAL PANEL
Es	POWER SUPPLY DRAIN INLET
Cd Ø 1"	CONDENSATE DRAIN
IN 1 Ø 1"	USER WATER INLET STANDARD
IN 2 Ø 1"	3 WAY WATER VALVE (OPTIONAL)
OUT 1 Ø 1"	USER WATER OUTLET STANDARD
IN 2 Ø 1"	USER WATER INLET DESUPERHEATER (OPTIONAL)
OUT 2 Ø 1"	USER WATER OUTLET DESUPERHEATER (OPTIONAL)

DP 550 - 750 - 950 (FARC)



11 . EU DECLARATION OF CONFORMITY

 Condair Group AG Gwattstrasse 17 8808 Pfäffikon Switzerland www.condair.com			DICHIARAZIONE DI CONFORMITÀ UE EU DECLARATION OF CONFORMITY												
Data/Date issuing date	Macchina Modello / Unit Model code and unit description	Numero di serie / Serial number unit serial number													
<p>Noi, firmatari della presente, dichiariamo sotto la nostra esclusiva responsabilità che l'insieme in oggetto, a cui questa dichiarazione si riferisce è conforme a tutte le disposizioni pertinenti delle seguenti direttive ed alle relative normative armonizzate dell'Unione Europea.</p> <p>We, the undersigned, hereby declare under our own responsibility that the assembly in question, to which this declaration refers, complies with all the provisions related to the following directives and harmonised European standards</p> <p>Direttive CEE / EEC directive:</p> <ul style="list-style-type: none"> - 2006/42 EC - 2014/30 EU - 2014/68 EU - 2011/65 EU - 2014/35 EU <p>Normative armonizzate / Harmonised standards:</p> <table style="width: 100%; border: none;"> <tr> <td>EN 60204-1:2018</td> <td>EN ISO 13857:2020</td> <td>EN 14276-2:2011</td> </tr> <tr> <td>EN 61000-6-1:2019</td> <td>EN 378-2:2017</td> <td>EN 13136:2019</td> </tr> <tr> <td>EN 61000-6-3:2013</td> <td>EN 14276-1:2011</td> <td>EN 12735-1:2020</td> </tr> <tr> <td>EN ISO 12100:2010</td> <td></td> <td>EN 12735-2:2016</td> </tr> </table>				EN 60204-1:2018	EN ISO 13857:2020	EN 14276-2:2011	EN 61000-6-1:2019	EN 378-2:2017	EN 13136:2019	EN 61000-6-3:2013	EN 14276-1:2011	EN 12735-1:2020	EN ISO 12100:2010		EN 12735-2:2016
EN 60204-1:2018	EN ISO 13857:2020	EN 14276-2:2011													
EN 61000-6-1:2019	EN 378-2:2017	EN 13136:2019													
EN 61000-6-3:2013	EN 14276-1:2011	EN 12735-1:2020													
EN ISO 12100:2010		EN 12735-2:2016													
<p>Il Costruttore / The Manufacturer</p>  <p>Condair Group AG Robert Merki</p>															

Maintenance and Service Report

Date _____ Job No. _____ Model _____

Type of Service: Commissioning Maintenance Serial number _____
 F-Gas inspection

Customer No./Name _____ City / Town _____
 Address _____ Phone number _____

Date	Start of work	End of work	Total work time (hours)	Travel time (hours)	Total travel distance (km)

Operating conditions

Measurements

Suction line temperature:	°C				
Liquid line temperature:	°C				
Evaporation pressure:	bar				
Condensation pressure:	bar				
Superheating:	K				
Subcooling:	K				
Outdoor temperature:	°C				
Discharge line temperature at compressor outlet:	°C				
Outlet air temperature/humidity:	°C / % RH				
Inlet air temperatur/humidtiy:	°C / % RH				
Outlet air flow:	m ³ /h				
Inlet air flow:	m ³ /h				

Name and signature of service technician

Name and signature upon acceptance of the work

Maintenance and Service Report

Date _____ Job No. _____ Model _____

Type of Service: Commissioning Maintenance Serial number _____
 F-Gas inspection

Customer No./Name _____ City / Town _____
 Address _____ Phone number _____

Date	Start of work	End of work	Total work time (hours)	Travel time (hours)	Total travel distance (km)

Operating conditions

Measurements

Suction line temperature:	°C				
Liquid line temperature:	°C				
Evaporation pressure:	bar				
Condensation pressure:	bar				
Superheating:	K				
Subcooling:	K				
Outdoor temperature:	°C				
Discharge line temperature at compressor outlet:	°C				
Outlet air temperature/humidity:	°C / % RH				
Inlet air temperatur/humidtiy:	°C / % RH				
Outlet air flow:	m³/h				
Inlet air flow:	m³/h				

Name and signature of service technician _____ Name and signature upon acceptance of the work _____

Maintenance and Service Report

Date _____ Job No. _____ Model _____

Type of Service: Commissioning Maintenance Serial number _____
 F-Gas inspection

Customer No./Name _____ City / Town _____
 Address _____ Phone number _____

Date	Start of work	End of work	Total work time (hours)	Travel time (hours)	Total travel distance (km)

Operating conditions

Measurements

Suction line temperature:	°C				
Liquid line temperature:	°C				
Evaporation pressure:	bar				
Condensation pressure:	bar				
Superheating:	K				
Subcooling:	K				
Outdoor temperature:	°C				
Discharge line temperature at compressor outlet:	°C				
Outlet air temperature/humidity:	°C / % RH				
Inlet air temperatur/humidtiy:	°C / % RH				
Outlet air flow:	m ³ /h				
Inlet air flow:	m ³ /h				

Name and signature of service technician

Name and signature upon acceptance of the work

Maintenance and Service Report

Date _____ Job No. _____ Model _____

Type of Service: Commissioning Maintenance Serial number _____
 F-Gas inspection

Customer No./Name _____ City / Town _____
 Address _____ Phone number _____

Date	Start of work	End of work	Total work time (hours)	Travel time (hours)	Total travel distance (km)

Operating conditions

Measurements

Suction line temperature:	°C				
Liquid line temperature:	°C				
Evaporation pressure:	bar				
Condensation pressure:	bar				
Superheating:	K				
Subcooling:	K				
Outdoor temperature:	°C				
Discharge line temperature at compressor outlet:	°C				
Outlet air temperature/humidity:	°C / % RH				
Inlet air temperatur/humidtiy:	°C / % RH				
Outlet air flow:	m ³ /h				
Inlet air flow:	m ³ /h				

Name and signature of service technician _____

Name and signature upon acceptance of the work _____

Maintenance and Service Report

Date _____ Job No. _____ Model _____

Type of Service: Commissioning Maintenance Serial number _____
 F-Gas inspection

Customer No./Name _____ City / Town _____
 Address _____ Phone number _____

Date	Start of work	End of work	Total work time (hours)	Travel time (hours)	Total travel distance (km)

Operating conditions

Measurements

Suction line temperature:	°C				
Liquid line temperature:	°C				
Evaporation pressure:	bar				
Condensation pressure:	bar				
Superheating:	K				
Subcooling:	K				
Outdoor temperature:	°C				
Discharge line temperature at compressor outlet:	°C				
Outlet air temperature/humidity:	°C / % RH				
Inlet air temperatur/humidtiy:	°C / % RH				
Outlet air flow:	m³/h				
Inlet air flow:	m³/h				

Name and signature of service technician _____

Name and signature upon acceptance of the work _____

CONSULTING, SALES AND SERVICE:



CH94/0002.00

Condair Group AG
Gwattstrasse 17, CH-8808 Pfäffikon (SZ)
Phone +41 55 416 61 11, Fax +41 55 416 62 62
info@condair.com, www.condair.com

 **condair**